

CORNING

ALTOS® Loose Tube, Gel-Free, All-Dielectric Cables with Binderless FastAccess® Technology, 12-72 Fibers

P/N 004-222-AEN
Issue 1

1. General

This procedure describes cable-end and mid-span sheath removal and fiber access of ALTOS® cables which feature Corning Optical Communications Binderless FastAccess® Technology (Figure 1).

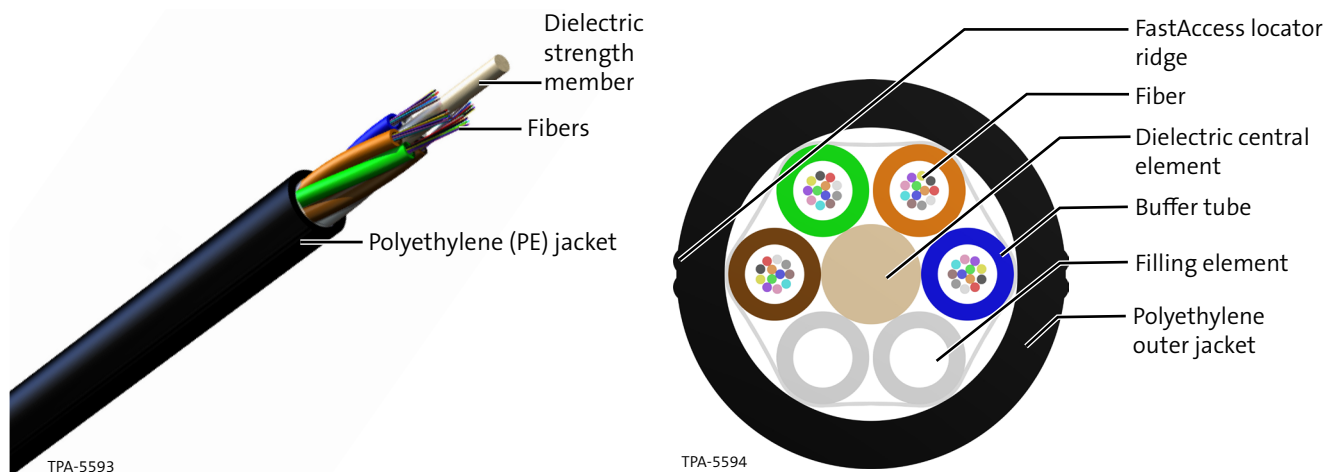

Figure 1

2. Precautions

2.1 Chemical Precautions

	WARNING: Fiber-Clean® Towelettes contain hydrocarbons. Apply in rooms having normal room ventilation. For prolonged and/or repeated use, gloves are recommended. Avoid eye contact. Keep away from open flames and ignition sources. If ingested, do not induce vomiting. Consult a physician. In case of eye contact, flush eyes with water for 15 minutes.
--	---

2.2 Personal Protection Equipment (PPE) Precautions

	CAUTION: Corning Optical Communications recommends the use of safety glasses (spectacles) conforming to ANSI Z87, for eye protection from accidental injury when handling chemicals, cables, or working with fiber. Pieces of glass fiber are very sharp and have the potential to damage the eye.
--	---

	CAUTION: The wearing of cut-resistant safety gloves to protect your hands from accidental injury when using sharp-bladed tools is strongly recommended. To minimize the chance of injury from sharp-bladed tools, always cut away from yourself and others. Dispose of used blades and armor scrap properly.
--	---

2.3 Laser Precautions

	CAUTION: Never look directly into the end of a fiber that may be carrying laser light. Laser light can be invisible and can damage your eyes. Viewing it directly does not cause pain. The iris of the eye will not close involuntarily as when viewing a bright light. Consequently, serious damage to the retina of the eye is possible. Should accidental eye exposure to laser light be suspected, arrange for an eye examination immediately.
---	---

2.4 Cable and Fiber Handling Precautions

	CAUTION: Fiber optic cable is sensitive to excessive pulling, bending, and crushing forces. Consult the cable specification sheet for the cable you are installing. Do not bend the cable more sharply than the minimum recommended bend radius. Do not apply more pulling force to the cable than specified. Do not crush the cable or allow it to kink. Doing so may cause damage that can alter the transmission characteristics of the cable; the cable may have to be replaced.
---	---

	CAUTION: The typical filler rod color in the cable described in this procedure is black. Careful attention should be taken to avoid accidental cutting of live buffer tubes; particularly white and black tubes. In mid-span applications, Corning Optical Communications recommends coiling all tubes and filler rods in the slack storage area of the splice closure; especially for cables with fiber counts above 96 fibers. Avoid cutting any filler rods unless necessary for storage space considerations. When in doubt regarding the buffer tube color code and filler rod placement, contact Corning Optical Communications Engineering Services for assistance prior to cutting.
---	--

	WARNING: Care must be taken while handling fibers during mid-span access procedures to avoid causing large deviations in optical power throughput on fibers carrying communications traffic. INTERRUPTION OF SYSTEM TRAFFIC MAY RESULT FROM NEGLIGENT HANDLING OF FIBERS.
---	---

	CAUTION: Cleaved or broken glass fibers are very sharp and can pierce the skin easily. Do not let these pieces of fiber stick to your clothing or drop in the work area where they can cause injury later. Use tweezers to pick up cleaved or broken pieces of glass fibers and place them on a loop of tape kept for that purpose alone. Good housekeeping is very important.
---	--

3. Tools and Materials

The following tools and materials are required to complete this procedure:

- Tape measure (Corning p/n 100305-01)
- Permanent marker
- Vinyl tape (100278-01)
- Scissors (100294-01)
- Ideal® tools: Small blue stripper for buffer tubes (45-163)
 Large blue stripper for outer jacket (45-164)
- Small slotted screwdriver (100332-01)
- Needle nose pliers
- Small cutters
- Optical Fiber Access Tool (OFAT) (OFT-000) and its instruction, SRP-004-014

4. Cable-end Sheath Removal and Fiber Access

4.1 Sheath Removal

Step 1: Calibrate both flat and round blades of Ideal® tool by trial and error on scrap cable or end of cable (see Figure 4).

Step 2: Refer to the documentation for the hardware in which you are installing the cable for the required sheath removal strip length.

Step 3: Mark the cable at the appropriate distance, plus 1 in (2.5 cm), from the cable end with at least three wraps of tape (Figure 2). *These wraps will permanently remain on the cable.*

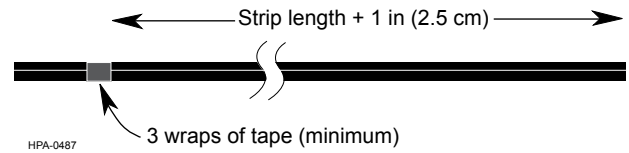

Figure 2

Step 4: At the end of the cable, locate the locator ridges which indicate the cable sheath's FastAccess® Technology features. These features appear as small longitudinal ridges on the cable sheath and are located 180 degrees from each other (Figure 3).

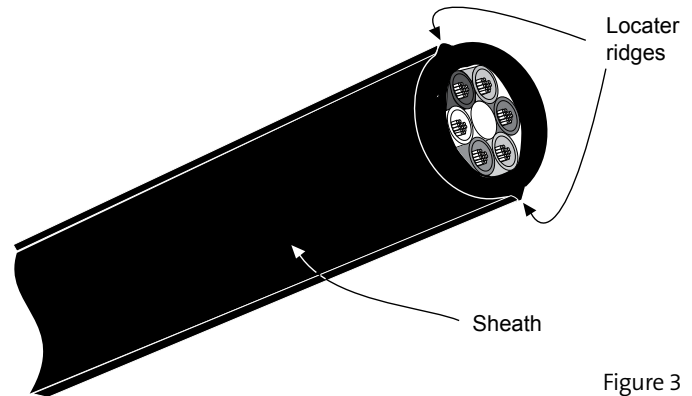

Figure 3

Step 5: Using the rounded blade on the end of the Ideal 45-164 tool, make a longitudinal cut on the two dual ridges opposite each other approximately 1-in from the end of the cable.

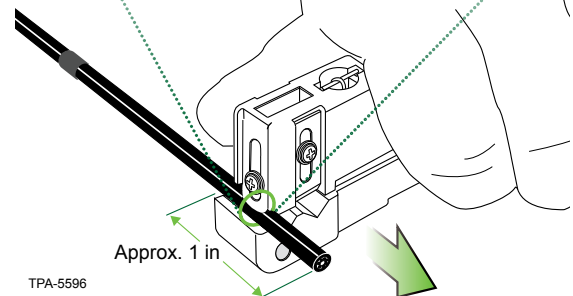
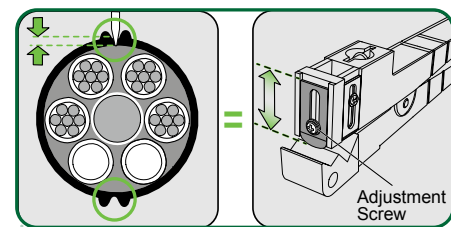

Figure 4

NOTE: Other options: Use needle-nose pliers or side-cutters to start tear (Figure 5).

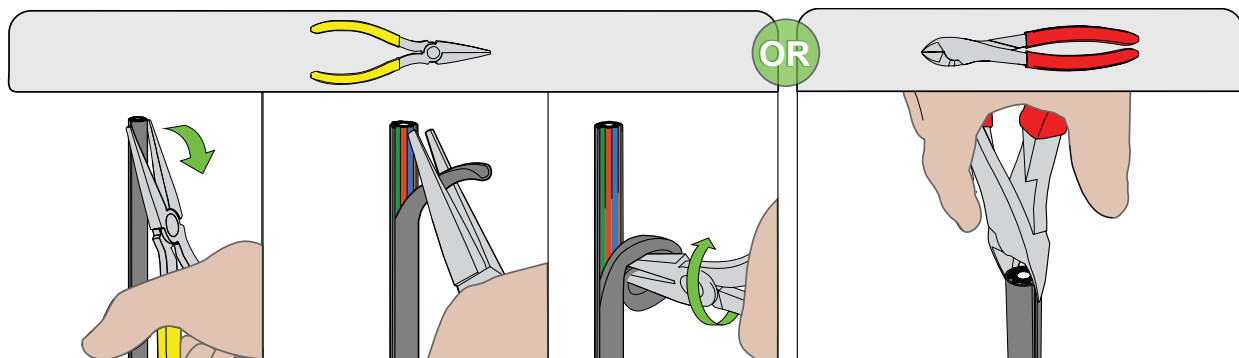

Figure 5

Step 6: With your fingers (Figure 6A) or needle-nose pliers (Figure 6B), remove the split pieces of outer jacket at the end of the cable (Figure 5). Continue to remove the jacket by pulling both sides to ring cut. An alternate method is to pull the Ideal® tool away from the cable enabling the round blade to pull out the jacket (Figure 6C).

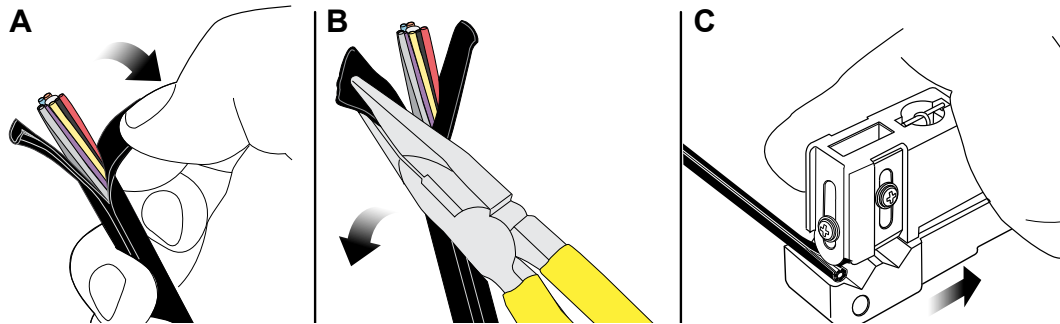

Figure 6

Step 7: Continue to remove the jacket by pulling both sides down to the tape mark and remove the jacket with side-cutter or small snips (Figure 7).

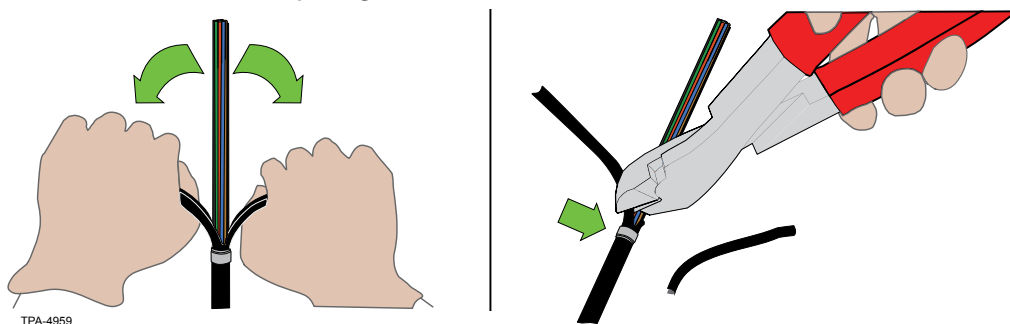

Figure 7

4.2 Buffer Tube Access

Step 1: Carefully unwind the buffer tubes from around the central member of the cable (Figure 8). Be careful not to bend or kink any of the buffer tubes.

Examine each buffer tube for damage. If you find any damaged tubes, report the damage to your supervisor. Do not cut out a damaged tube or continue the installation with damaged fibers.

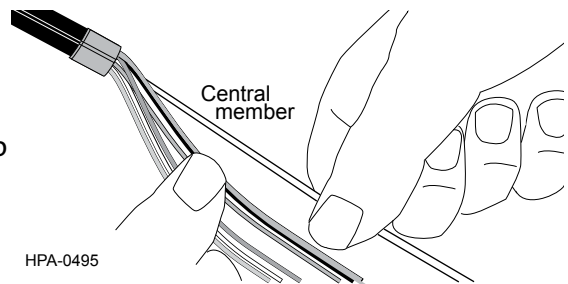

Figure 8

NOTE: The central member length called for in this procedure should be adequate for most hardware – most closures will require additional trimming of the central member. Always verify the central member length your installation requires before cutting.

Step 2: Use side cutters to cut the dielectric central member to a length of 6 in (15 cm) (Figure 9).

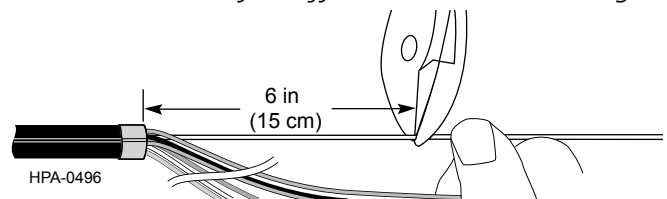

Figure 9

4.3 Cable-End Fiber Access

NOTE: Only access the fibers when you are ready to terminate or splice them.

Before using the coaxial cable stripper, follow the adjustment and test procedures in SRP-005-007, Scoring Fiber Optic Tubes with a Coaxial Cable Stripper, to make sure that the stripper is properly adjusted and that it has a sharp blade.

Step 1: Consult the instructions of the hardware in which the fibers will be installed for the required buffer tube length. Measure and mark this length on the buffer tubes with a permanent marker.

Step 2: To score the first tube:

- Position the stripper's blade on the scoring mark.
- Hold the tube steady with one hand to prevent it from twisting.
- Use your other hand to rotate the tool around the tube two to three complete turns to score it (Figure 10).
- Remove the tool from the tube.

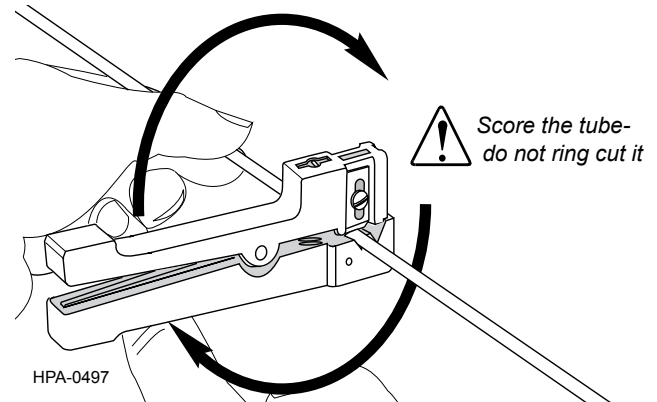

Figure 10

Step 3: Carefully flex the tube to break it at the score point (Figure 11).

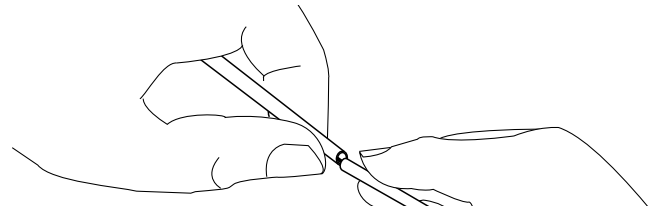

Figure 11

Step 4: Slide the scored section of tube off of the fibers (Figure 12).

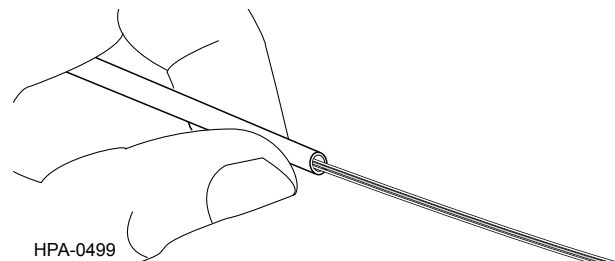

Figure 12

Step 5: Use scissors to trim 1 in (2.5 cm) from the end of the fibers. The fibers are now ready to be cleaned and terminated (Figure 13).

Step 6: Repeat Steps 1-5 on the remaining buffer tubes/fibers.

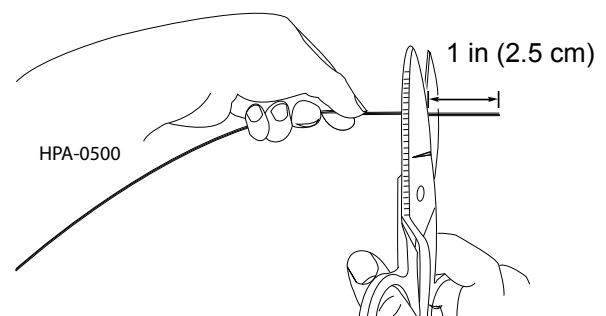

Figure 13

5. Mid-span Sheath Removal and Fiber Access

This procedure is dependent upon sufficient slack cable for access and uses the OFT-000, Optical Fiber Access Tool. The minimum amount of cable slack is determined as follows:

Slack needed = 60 x cable diameter + 42 in (105 cm):

for example, for a 0.5 in (1.25 cm) OD cable,

60 X 1.25 = 75cm plus 105 cm = 72 in (180 cm) of slack

Add any necessary additional slack needed to reach the splicing workstation from a pole or manhole.

- Step 1:** Prepare the tie-in (drop) cable according to the appropriate cable stripping procedure. If the tie-in cable is armored and grounding is required, install a grounding clip or connector at this time. Set the tie-in cable aside in a secure place.
- Step 2:** Determine the center of the slack loop of the cable being accessed and mark it with a permanent marker.
- Step 3:** Measure half of the total length to be accessed in each cable direction from the loop mid-point.
- Step 4:** Wrap each of these points with at least 3 wraps of vinyl tape. The total length from tape wrap to tape wrap should equal the full desired strip length (Figure 14). *These wraps will permanently remain on the cable.*

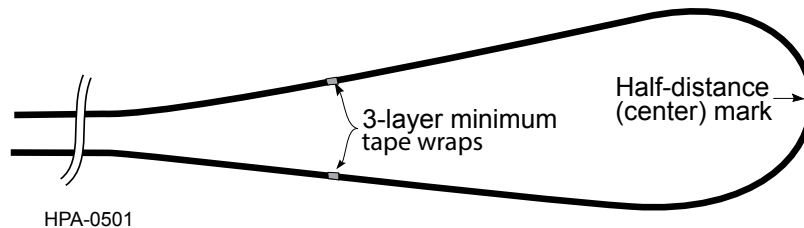

Figure 14



WARNING: Care must be taken while handling fibers during mid-span access procedures to avoid causing large deviations in optical power throughput on fibers carrying communications traffic. INTERRUPTION OF SYSTEM TRAFFIC MAY RESULT FROM NEGLIGENT HANDLING OF FIBERS.

5.1 Mid-span Sheath Removal

- Step 1:** Use the Ideal® tool to make the first ring cut at one of the tape marks (Figure 15).

IMPORTANT: *The Ideal tool must be calibrated on a scrap piece of cable.*

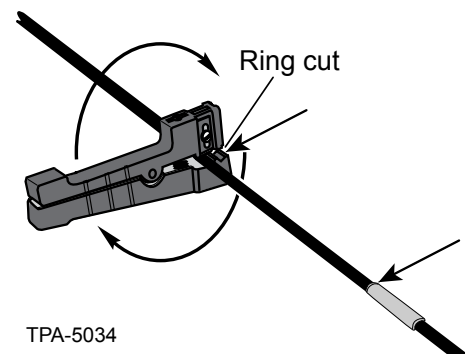

Figure 15

Step 2: Make the second ring cut at the second tape location, or simply trim off jacket (Figure 16).

Step 3: Use the end of the Ideal® tool with a rounded blade installed. Make an approximately 1-in longitudinal cut two ridges on each side (Figure 16).

NOTE: An option is to make one ring cut in center and remove jacket exposing tubes on each side of ring cut, and then trim off jacket.

Step 4: After the last 1-in cut, either use fingers, needle-nose pliers, sheath knife, or Ideal tool round blade to pull jacket away from cable. See Figure 6.

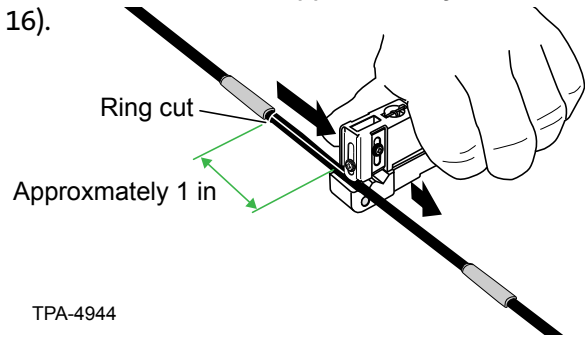

Figure 16

Step 5: Using care to avoid damaging the cable core, use side cutters or scissors to trim off the split sheath sections at the tape wrap (Figure 17).

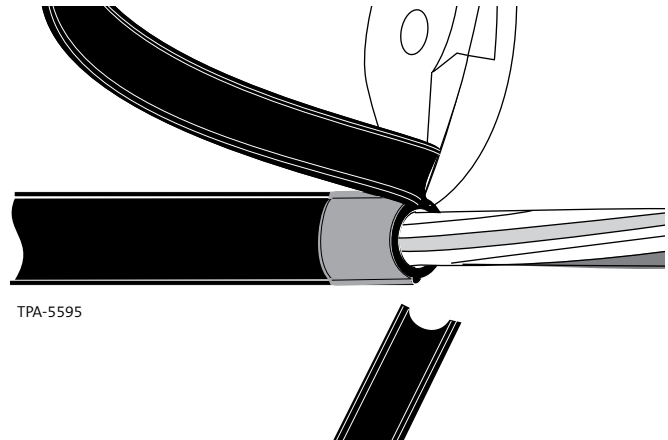

Figure 17

Step 6: Cable core is ready to be accessed.

Step 7: Locate the switch back center where the direction of the buffer tubes' wrap around the central member switches to the opposite direction (Figure 18).

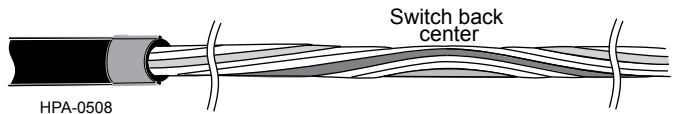

Figure 18

Step 8: Working from the switch back center back to the tape wraps, carefully unwind the buffer tubes from around the central member of the cable (Figure 19). Be careful not to bend or kink any of the buffer tubes.

NOTE: The central member length called for in this procedure should be adequate for most hardware – most closures will require additional trimming of the central member. Always verify the central member length your installation requires before cutting.

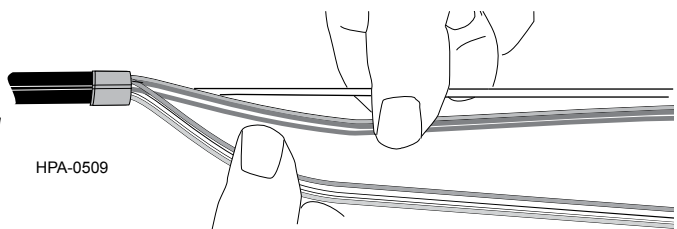

Figure 19

Step 9: Use side cutters to cut the dielectric central member to a length of 2.6 in (6.6 cm) from each end of the cable sheath (Figure 20).

Step 10: Mount the ALTOS® cable into the closure or hardware along with the drop cable according to the closure/hardware instructions (see Figure 22). Depending upon the type of closure or hardware being used, install any cable mounting hardware and sealants at this time.

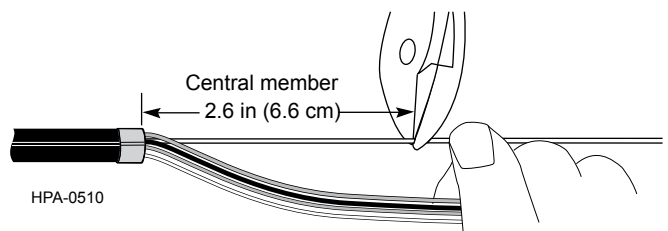

Figure 20

5.2 Mid-span Fiber Access

- Step 1:** Read and completely understand SRP-004-014, Corning Optical Communications OFT-000 Optical Fiber Access Tool (OFAT) (Figure 21). This procedure describes how to access fibers in a buffer tube with the OFAT.
- Step 2:** Access the appropriate buffer tube(s) as described in the OFAT tool's instructions (Figure 22).
- Step 3:** Determine which end of the fiber should be cut and do so with a pair of scissors. The fibers are now ready to be cleaned and terminated.

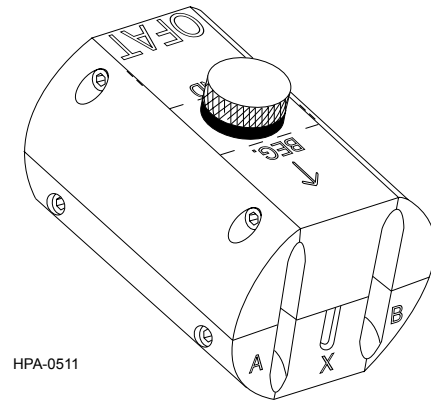

Figure 21

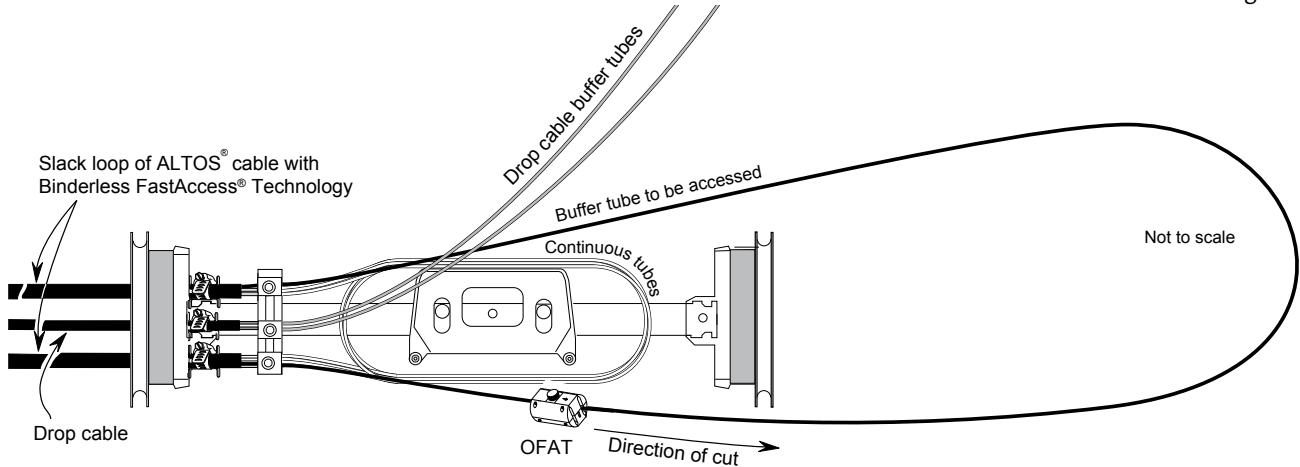

Figure 22