

# CORNING

## EDGE8® Solution

003-1002-AEN

Issue 9

related literature   Search <a href="http://www.corning.com/opcomm">www.corning.com/opcomm</a> . Click on “Resources.”	
003-1010-AEN	EDGE8® Solution with Fixed Tray
003-825-AEN	EDGE and EDGE8 Fiber Zone Boxes
003-991-AEN	EDGE Port Replication Housing
003-892-AEN	EDGE and EDGE8 Solution Single Module Housing
003-1019-AEN	EDGE8 MTP Adapter Panels
006-407-QSG-AEN	Field Tool for MTP® PRO Connectors Quick Start Guide

## Table of Contents

1.	General.....	3
2.	Carton Contents.....	3
3.	Tools and Materials Required.....	3
3.1	Tools.....	3
3.2	Materials.....	3
4.	Installation.....	4
4.1	Rack or Frame Mounting.....	4
4.2	Install Trunk Cables.....	4
4.2.1	Trunk Cable Placement with the Pulling Grip.....	6
4.2.2	Pulling Grip Removal.....	6
4.3	(OPTIONAL) Install CDF Bracket.....	8
4.4	Install Trunk Cables from Either Side of the Housing.....	9
4.4.1	Installing Trunk Cable Using Keyhole Cradle.....	9
4.4.2	Installing Trunk Cable with Keyhole Adapter.....	9
4.5	Install Trunk Cables from Rear of Housing.....	10
4.6	(OPTIONAL) Remove Housing Trunk Plate.....	11
4.7	Install EDGE8® Standard Modules.....	12
4.7.1	Into EDGE8-01U-SP, EDGE8-02U, and EDGE8-04U Housings.....	12
4.7.2	Into EDGE8-01U Housing.....	13
4.8	Install EDGE8 Port Breakout Modules.....	14
4.8.1	Into EDGE8-01U-SP, EDGE8-02U, and EDGE8-04U Housings.....	14
4.8.2	Into EDGE8-01U Housing.....	15
4.9	Connect Jumpers to EDGE8 Modules.....	16
4.10	Install MTP® Adapter Panels.....	16
4.10.1	Connecting MTP Trunk Cable to Rear of MTP Adapter Panel — Initial Mating.....	17

4.10.2	Connecting Harnesses, MTP® Jumper, MTP Conversion Harnesses, or Extender Trunk to the Front of the MTP Adapter Panels— Initial Mating .....	18
5.	Recordkeeping .....	19
5.1	Hardware Labeling .....	19
5.2	Cable/Jumper Labeling .....	23
6.	Troubleshooting and Maintenance.....	24
6.1	Testing .....	24
6.2	Replace EDGE8® Module.....	25
6.3	Remove Trunk Cable .....	25
6.3.1	Cable in Keyhole Cradle .....	25
6.4	Changing the Polarity of an LC Uniboot Connector .....	26
6.5	Changing the Polarity of an MTP® Adapter and Connector .....	26
6.6	Connector Care and Cleaning —Post Initial Mating .....	26

## 1. General

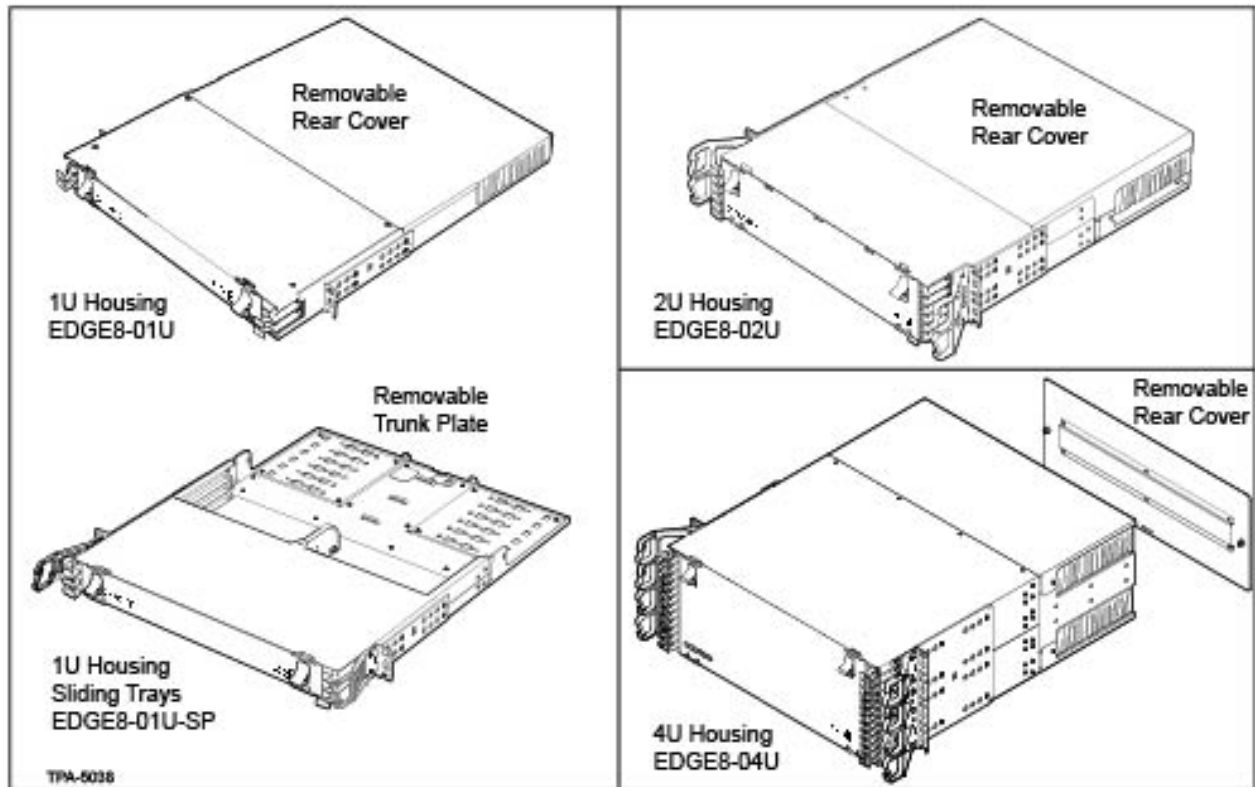

Figure 1 — EDGE8™ Housings

This documentation describes installation of the EDGE8® 1U, 1U-SP, 2U, and 4U Housing Solutions (Figure 1). Except where installation of another housing is unique, only the 4U housing is illustrated.

## 2. Carton Contents

- Housing, either 1U, 1U-SP, 2U, or 4U rack-height
- Mounting hardware kit, either for rack or frame
- (1U-SP, 2U and 4U housings ONLY) (2) Fiber management fingers

## 3. Tools and Materials Required

### 3.1 Tools

- Phillips screwdriver
- Reel stand

### 3.2 Materials

- Hook-and-loop straps

## 4. Installation

### 4.1 Rack or Frame Mounting

**Step 1:** Identify the position on the rack where the housing will be installed and partially install screws to rest the mounting brackets on Figure 2.

**Step 2:** Move brackets forward or backward for desired frontal projection and rest the mounting brackets behind the screw heads just installed in the rack.

**Step 3:** Install screws into the rack through the mounting brackets.

**Step 4:** If installing a 2U or 4U housing, slide the fiber management fingers onto the housing.

**NOTE:** *Installation of fiber management fingers is essential to ensure proper jumper management.*

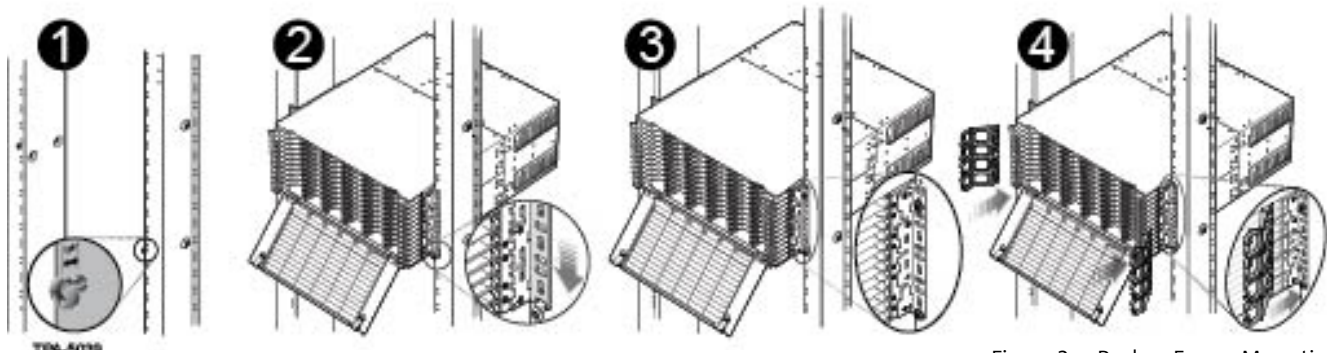

Figure 2— Rack or Frame Mounting

### 4.2 Install Trunk Cables

The EDGE8® trunk cable is supplied with factory-installed protection/pulling grips (Figure 3) to protect the connectors and their fibers by coupling the pulling load back to the cable. The cradle is used to install the furcation plug into the housing.

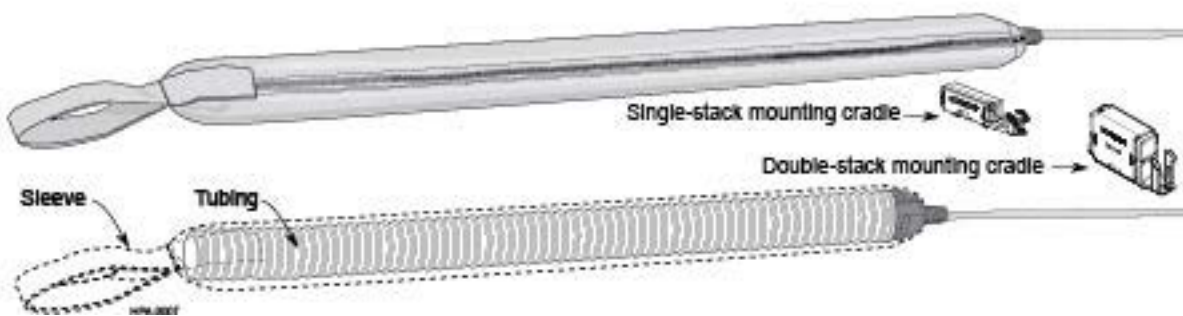

Figure 3— Cable with Pulling Grips



### Weather Precautions

- Always follow the recommended storage temperature guidelines for the cable when storing a trunk/pigtail. Each cable type will have a storage temperature rating that can be found on the product specification sheets. Storage outside of these ranges can cause damage to the cables.
- Cable type, pulling grip and reel material dictate indoor or outdoor storage. Plywood reels should never be stored outdoors. Doing so may cause damage to the reel. Cables designed specifically for indoor use should never be stored outdoors. Indoor cables are also not UV rated, and jacket damage can occur from storing indoor cables in sunlight. Not all pulling grips are watertight and suitable for exposure to weather. Trunks/pigtails with non-watertight grips will need to be stored inside, even though the cable may be suitable for outdoor storage. Trunks greater than 144 fibers do not have watertight pulling grips. These trunks should be stored in a dry location to ensure proper performance of the connectors.



### Reel Handling

- Always lift a plywood or wooden reel by both flanges. Do not pick up a reel by one flange. Picking up a reel by one flange can cause the reel bolts to loosen leading to cable damage.
- Never drop a reel. When a reel is dropped, damage to the cable can occur and flange bolts can loosen. Any dropped reel should be thoroughly evaluated for cable/reel damage.
- Do not allow reels to bump into one another. Allowing the flanges to rub or bump the cable can cause cable or fiber damage.
- Pay attention to reel labels. Reels should always be stored in the orientation outlined on the reel. Observe “This End Up” arrows on reels or boxes.
- Ensure that all flange bolts are tight prior to loading a reel for pulling. Changes in temperature and humidity can cause the wooden/cardboard components of the reel to expand and contract allowing the flange bolts to loosen over time. Loose flange bolts may cause the cable to become entangled and possibly damage the cable during installation.



**IMPORTANT:** The pulling grips installed on preconnectorized cables contain the connectors and their subunits. Unlike conventional pulling grips, do not cut off the grip and cable inside it upon the completion of cable installation. Remove the pulling grip from over the connectors and subunits only as described in this procedure. Failure to do so may result in damage or loss of the connector assemblies.

Do not attempt to disassemble the pulling grip before the cable is pulled into place. Doing so may cause the pulling grip to fail.

For detailed information on cable placement, and a comprehensive list of applicable safety precautions, refer to SRP-005-014, Fiber Optic Cable Placing - Intrabuilding. It is necessary to have radio or other two-way communications between pull points. Should a kink or other pulling problem occur, instant communication is vital to stop the pulling operation to prevent cable and/or connector damage.



**CAUTION:** Do not use any type of lubricant when installing this series of pulling grip.



**CAUTION:** These grips are intended to be placed and pulled by hand. Do not use any mechanical pulling devices on this series of grip.



**CAUTION:** This preconnectorized pulling grip has a maximum tensile rating of 100 pounds (44.5 kg). NEVER EXCEED THIS TENSION DURING INSTALLATION. The pulling grip has a minimum bend radius of 18 inches (45.72 cm). Refer to the EDGE8™ specification sheet for cable/grip dimensions and appropriate duct sizes.



**CAUTION:** Fiber optic cable is sensitive to excessive pulling, bending, and crushing forces. Consult the cable specification sheet for the cable you are installing. Do not bend the cable more sharply than the minimum recommended bend radius. Do not apply more pulling force to the cable than specified. Do not crush the cable or allow it to kink. Doing so may cause damage that can alter the transmission characteristics of the cable; the cable may have to be replaced.

#### 4.2.1 Trunk Cable Placement with the Pulling Grip

**NOTE:** This procedure assumes that a pull line has been placed in the duct route and that the equipment necessary to maintain the bend-radius of the pulling grip is in position.

**Step 1:** If necessary, remove the corrugated reel from its protective shipping box or pallet.

**Step 2:** Place the cable reel on a reel stand so that the pulling grip/cable will pay-off the top of the reel (Figure 4).

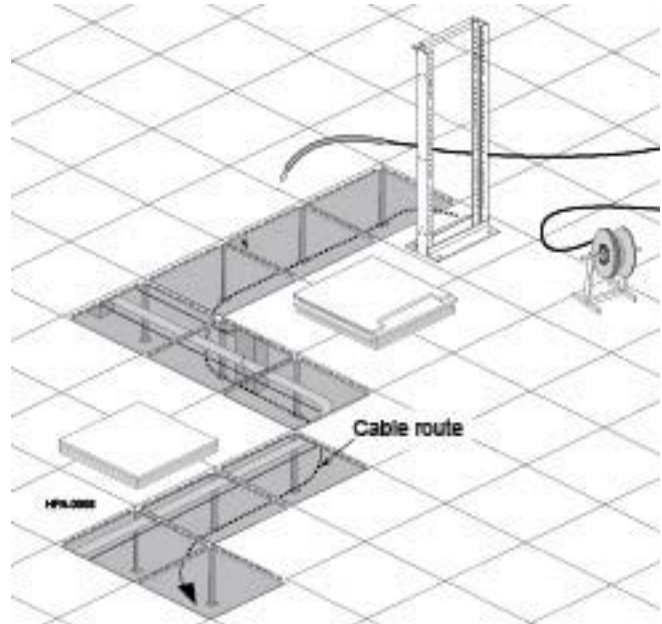

Figure 4— Reel Stand and Cable Route

**Step 3:** Attach a pull line to the pulling loop at the end of the sleeve (Figure 5).

**Step 4:** Place the cable using your company's standard practice, taking care not to exceed either the minimum bend radius or tensile rating of the grip.



Figure 5— Pull Line

#### 4.2.2 Pulling Grip Removal

**Step 1:** Remove the pull line and clean any dirt or debris from the outer surfaces of the sleeve.

**IMPORTANT:** Disassemble the pulling sleeve on a work surface free from dirt, excessive heat, or any solvents.

**Step 2:** Lift the hook-and-loop flaps to expose the zipper pull. While holding the sleeve's pulling loop with one hand, unzip the sleeve (Figure 6).

**Step 3:** Remove the cloth sleeve from around the grip.

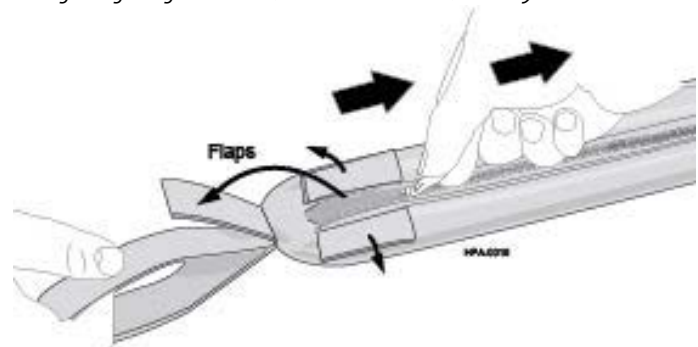

Figure 6— Unzipping the Sleeve

**Step 4:** With the grip lying on a work surface, grasp the coupler at the cable-end of the trunk cable. With a slight twisting motion, pull the corrugated tube away from the coupler with your other hand (Figure 7).

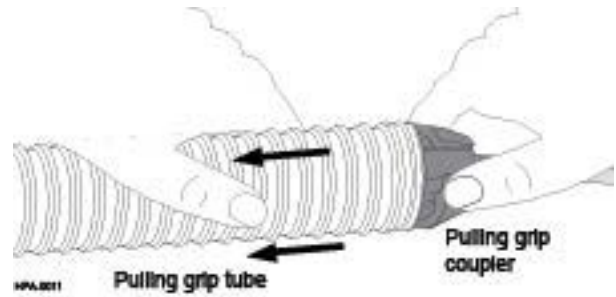

Figure 7— Grip Disassembly

**Step 5:** Slowly slide the tubing away from the coupler and its connector legs (Figure 8).

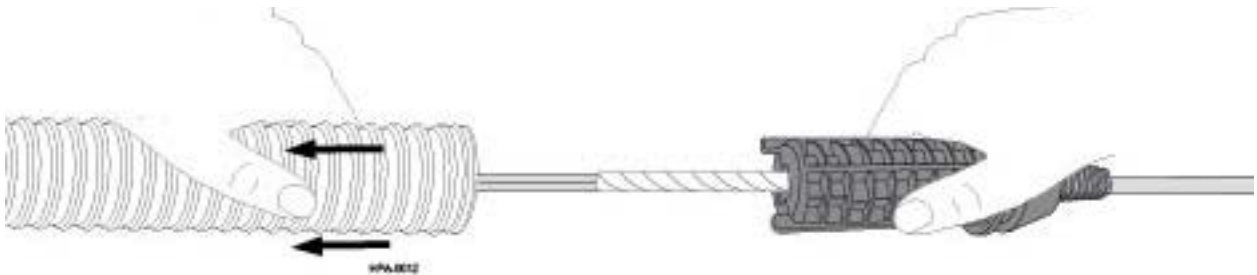

Figure 8 — Tubing Removal

**Step 6:** Use the tabs on the furcation end of the coupler to separate the coupler's two halves.

**Step 7:** Remove the coupler halves from the trunk furcation body and dispose of the coupler assembly (Figure 9).

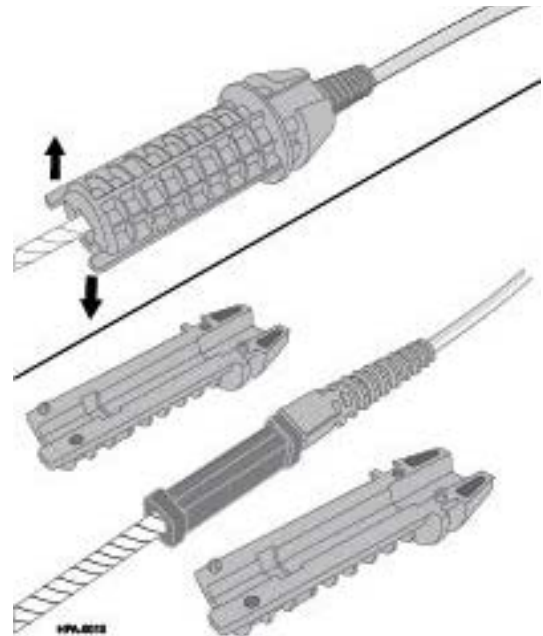

Figure 9— Remove Coupler Halves

## 96- and 144-fiber Trunks:

**Step 8:** Starting with the mesh bag closest to the furcation body, remove the tape and mesh to expose the first set of three folded legs (Figure 10). If applicable, unfold the legs from around the bend control device.

Repeat this step on the middle mesh bag, and then conclude by removing the end mesh bag.

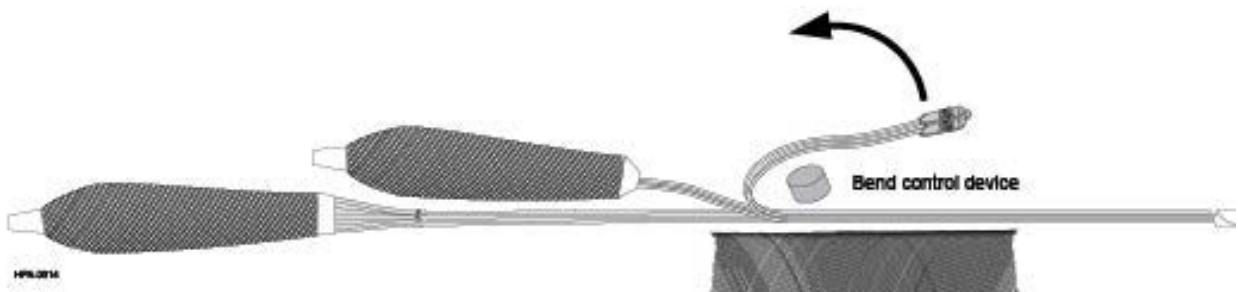

Figure 10 — Mesh Bag Removal



### 4.3 (OPTIONAL) Install CDF Bracket

An optional CDF bracket may be installed external to the housing on the frame to provide additional cable trunk installation positions and/or strain-relief. It supports incoming cable installation from the top or bottom of the frame into the housing. The bracket can hold keyhole cradles or U-clip furcation trunk holders (ordered separately) and is available in three sizes:

- EDGE-CDF-RJ04-BKT — 4-position furcation trunk holder
- EDGE-CDF-RJ08-BKT — 8-position furcation trunk holder
- EDGE-CDF-RJ12-BKT — 12-position furcation trunk holder

CDF brackets support use of extender trunks. If using an IBU (vertical manager) between frames, extender trunks mounted to the CDF bracket on the back side of the frame must transition to the front using a “pass-through” IBU system.

**Step 1:** Align bracket within the same height of the 4U housing.

**Step 2:** Install bracket using two 12-24 screws (Figure 11). Allow enough clearance when routing trunks from the bracket into the housing to ensure bend radius is maintained when trunks enter the housing.

**NOTE:** *If greater bend radius control of cable is required, position the bracket slightly above or below the roof of the housing, depending upon the direction the cable is entering the housing.*

**Step 3:** Insert furcation plug into cradle as seen in Figure 12 or Figure 13 and mount cradle onto CDF bracket (Figure 11).

**Step 4:** Then route trunks inside the housing through the brushed cable entry slots. Terminate the MTP® connector at the back of the LC module or MTP adapter panel.

**NOTE:** *In some cases, variations in the length of the trunk leg make it necessary to mount the trunk cradle further out on the CDF bracket closer to the cable entry slot to avoid pulling on the leg when accessing the tray from the front side of the housing.*

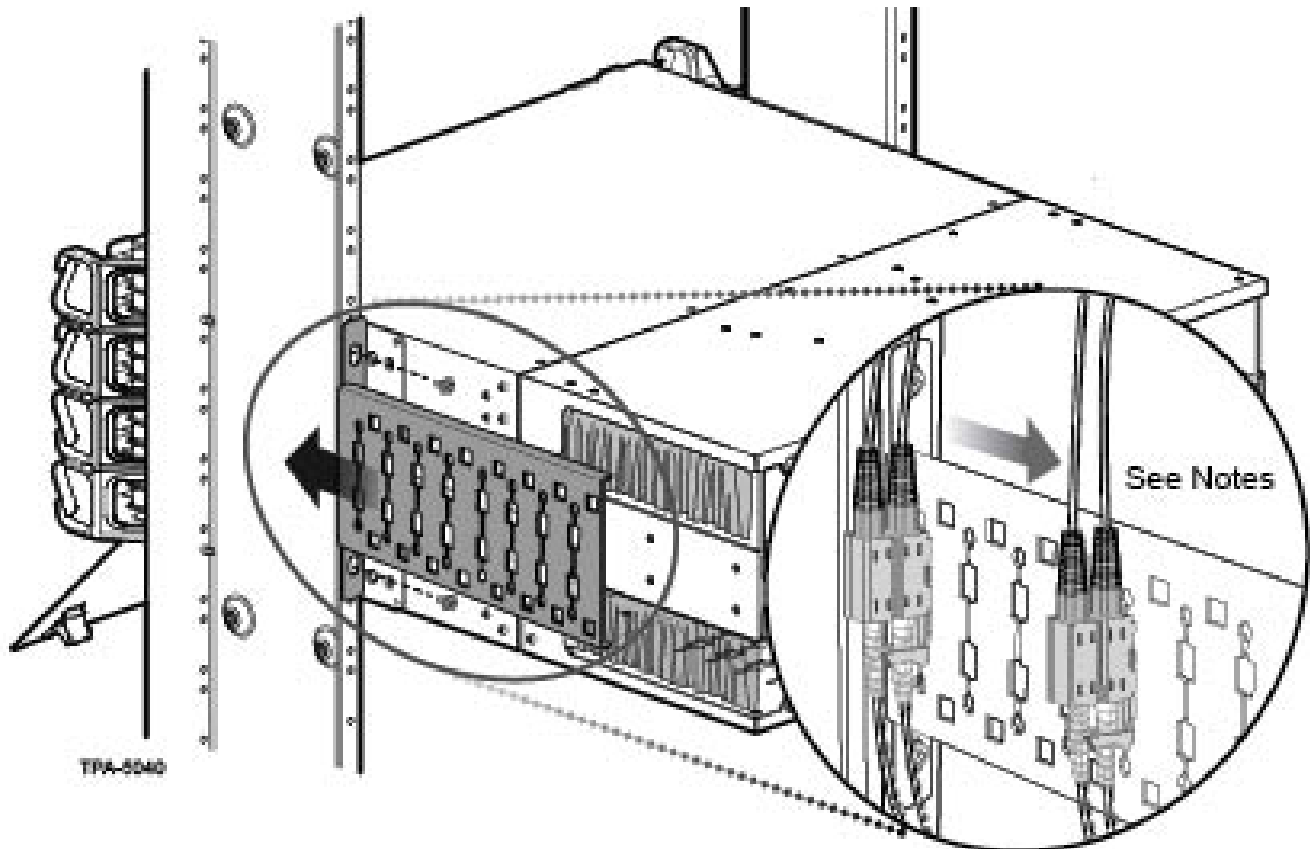

Figure 11 — Install CDF Bracket



## 4.4 Install Trunk Cables from Either Side of the Housing

If necessary to install trunk cables from the rear of a housing, refer to Section 4.5 for details on reorienting the backplates to accommodate rear cable entry.

In a 4U housing, trunk cables may be installed into the backplates in the top of the housing in an upside-down orientation, if desired or necessary, to accommodate additional cables.

### 4.4.1 Installing Trunk Cable Using Keyhole Cradle

**Step 1:** Remove the access or rear cover from the housing to reach the backplate (Figure 1).

**Step 2:** Open cradle provided inside the reel and press each trunk cable furcation plug into cradle (Figure 12 - double-stack cradle or Figure 13 - single-stack cradle).

**NOTE:** One double-stack cradle (shown in Figure 12) is provided with the trunk cable.

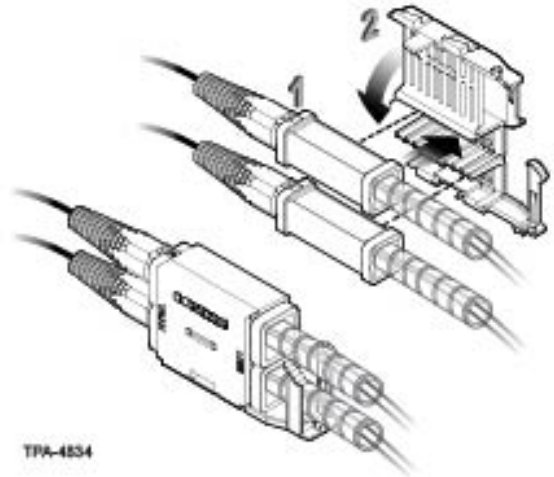

**Step 3:** Open rear housing door. Route cables into housing through side openings.

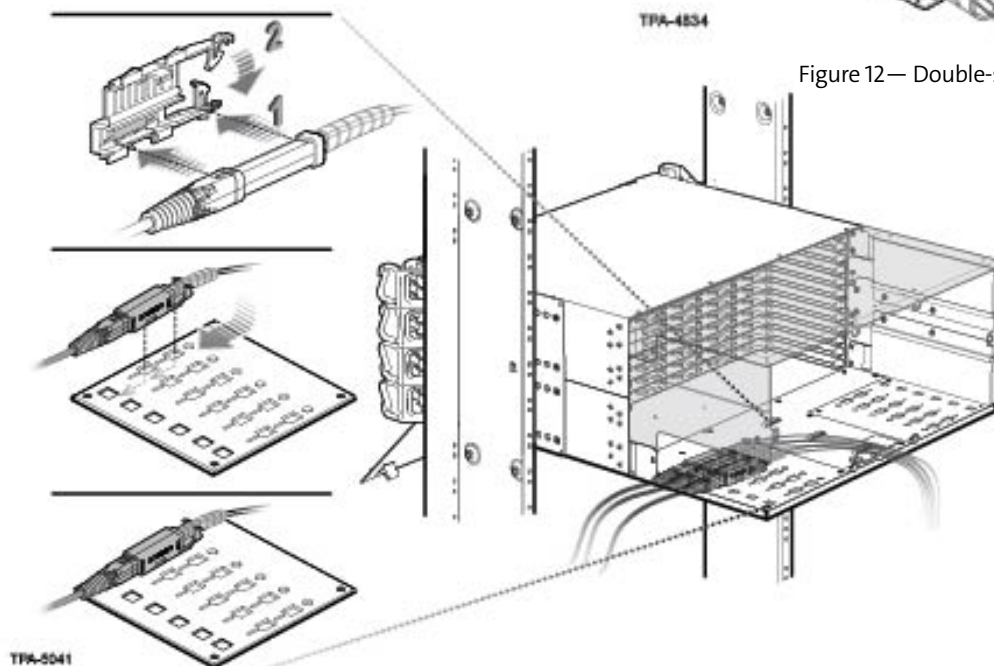

Figure 12— Double-stack Keyhole Cradle

Figure 13 — Install Trunk Cables with Keyhole Cradle

**Step 4:** Insert cradle feet into backplate and slide into slots to lock in place.

**Step 5:** Repeat for all trunk cables and allow connectorized MTP® legs to flow out the rear of the housing until ready to mate in the appropriate module or panel.

### 4.4.2 Installing Trunk Cable with Keyhole Adapter

**Step 1:** Orient keyhole adapter to where leg side of trunk is near keyhole adapter release tabs (Figure 14).

**Step 2:** Align groove on furcation body with ridge in keyhole adapter.

**Step 3:** Once the groove is aligned, slide down and back until furcation body is completely mounted on the keyhole adapter.

**Step 4:** Align keyhole adapter with mounting plate. Push down and slide keyhole adapter back until it locks into place.

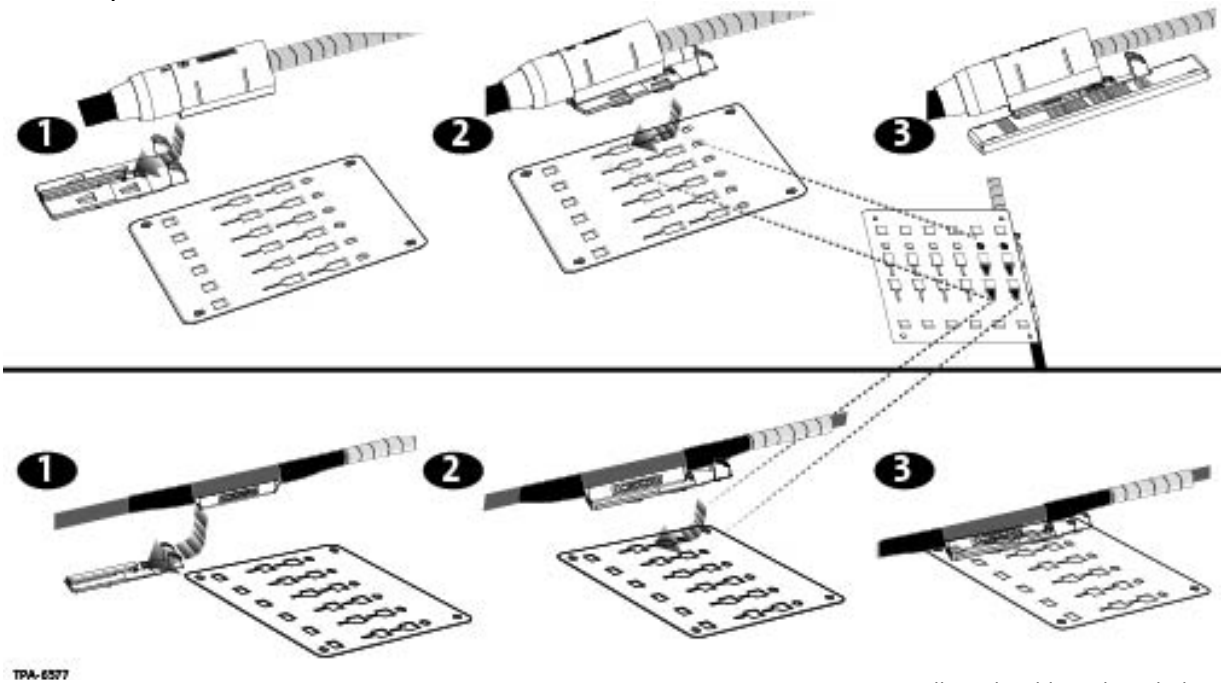

TPA-6577

Figure 14— Install Trunk Cable with Keyhole Adapter

#### 4.5 Install Trunk Cables from Rear of Housing

If rear cable entry into the housing is desired or necessary, the backplates must be turned 180 degrees before installing the cables.

**Step 1:** Remove existing backplates by removing the four screws (Figure 15).

**Step 2:** Turn the backplate 90 degrees as shown and reinstall the four screws.

**Step 3:** Insert cradle feet into backplate as shown in Figure 13 or Figure 14 for your cradle type.

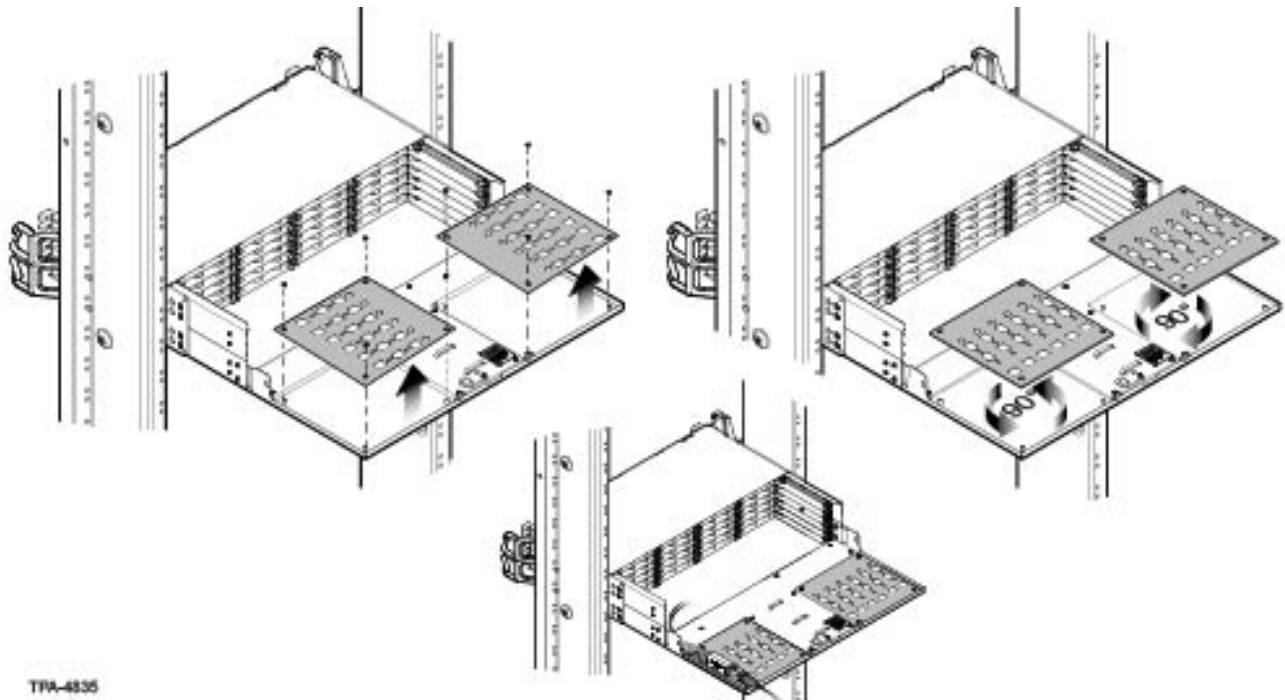

TPA-6535

Figure 15 — Reorient Backplate

## 4.6 (OPTIONAL) Remove Housing Trunk Plate

If cable entry strain-relief is accomplished in a location external to the housing, the trunk plate may be removed to allow more room behind the housing (Figure 16).

**Step 1:** (For 4U housing only) Remove side panel from each side of the housing.

**Step 2:** Remove any screws holding the access panels to the housing.

**Step 3:** Remove any screws holding the trunk plate to the housing.

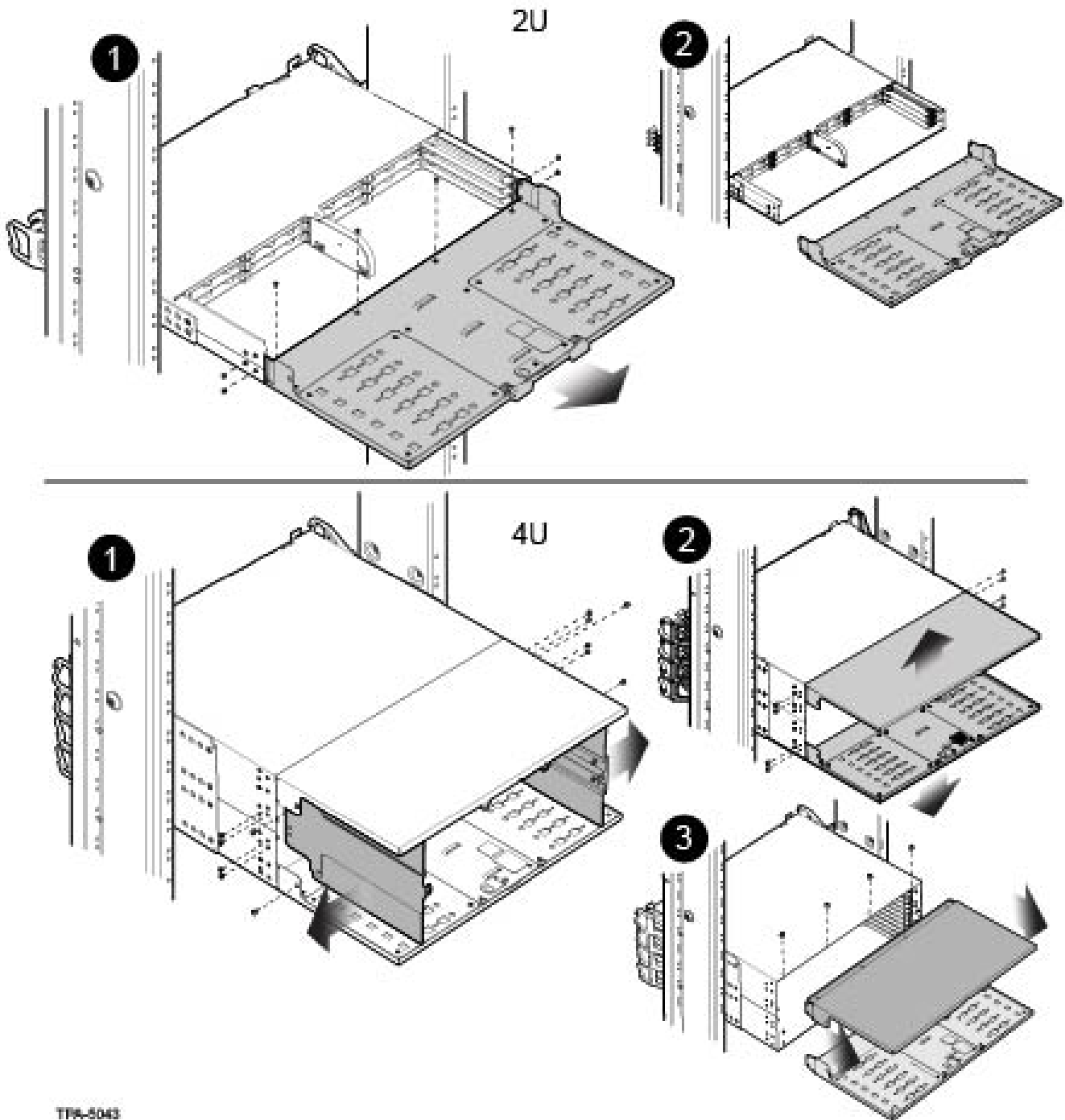

TPA-5043

Figure 16 — Remove Back Deck

## 4.7 Install EDGE8® Standard Modules

### 4.7.1 Into EDGE8-01U-SP, EDGE8-02U, and EDGE8-04U Housings

**Step 1:** Remove the MTP® connector dust cap by pulling on the dust cap while holding the connector body/housing/shroud. For the initial mating, do not clean or scope connectors. Corning CleanAdvantage™ connectors are shipped with an optimized dust cap to maintain cleanliness for the first use.



Figure 16A

**CAUTION:** Scoping Corning CleanAdvantage connectors increases the risk of adding contamination to the system. CleanAdvantage technology is designed for mating connectors without cleaning or scoping before the initial installation.

- Step 2:** Mate the MTP connector(s) into the adapter(s) at the back of the module (Figure 17) with the MTP key down/opposite the module label.
- Step 3:** Starting with lower right corner (Tray 1, slot A), insert module from the rear until it locks into place. Load all trays from right to left, bottom to top in the housing, as seen from the back.
- Step 4:** Loop slack as shown in Figure 17, leaving enough slack to pull out trays without violating the minimum bend radius.
- Step 5:** Repeat for all modules.
- Step 6:** Loosely capture fiber slack with hook-and-loop straps, if desired (Figure 17).

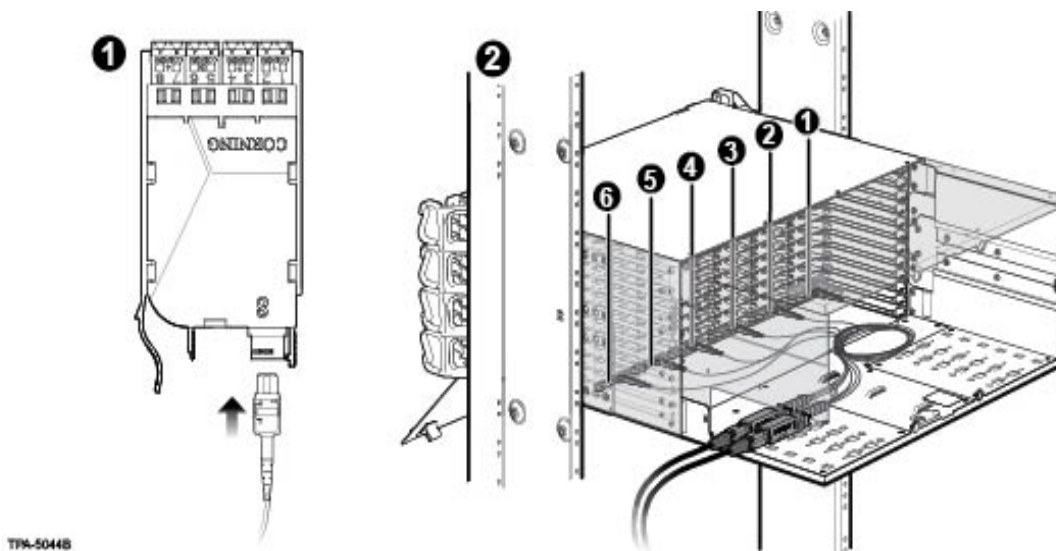

Figure 17 — Install EDGE8™ Standard Modules



**CAUTION:** When removing the trays, position yourself in the center of the rack and use both hands to pull the tray out. Failure to do so may damage the tray guides or cause shelf movement past the detents.

**Step 7:** Return to front of housing and pull out each tray to test that tray freely pulls out without stress on the cables. If restriction in movement is felt, return to rear of the housing and adjust slack to relieve tension on cables.

#### 4.7.2 Into EDGE8-01U Housing



**CAUTION:** When removing the trays, position yourself in the center of the rack and use both hands to pull the tray out. Failure to do so may damage the tray guides or cause shelf movement past the detents.

**Step 1:** Press latches down to open and lower front door.

**Step 2:** Using tabs on the side of the drawer, lift and pull out drawer horizontally until reaching hard stops (Figure 18).

**Step 3:** Support the drawer and lower it to the angled position. Remove rear access panel to allow easier access to mount the trunk cables and connect the trunk legs.

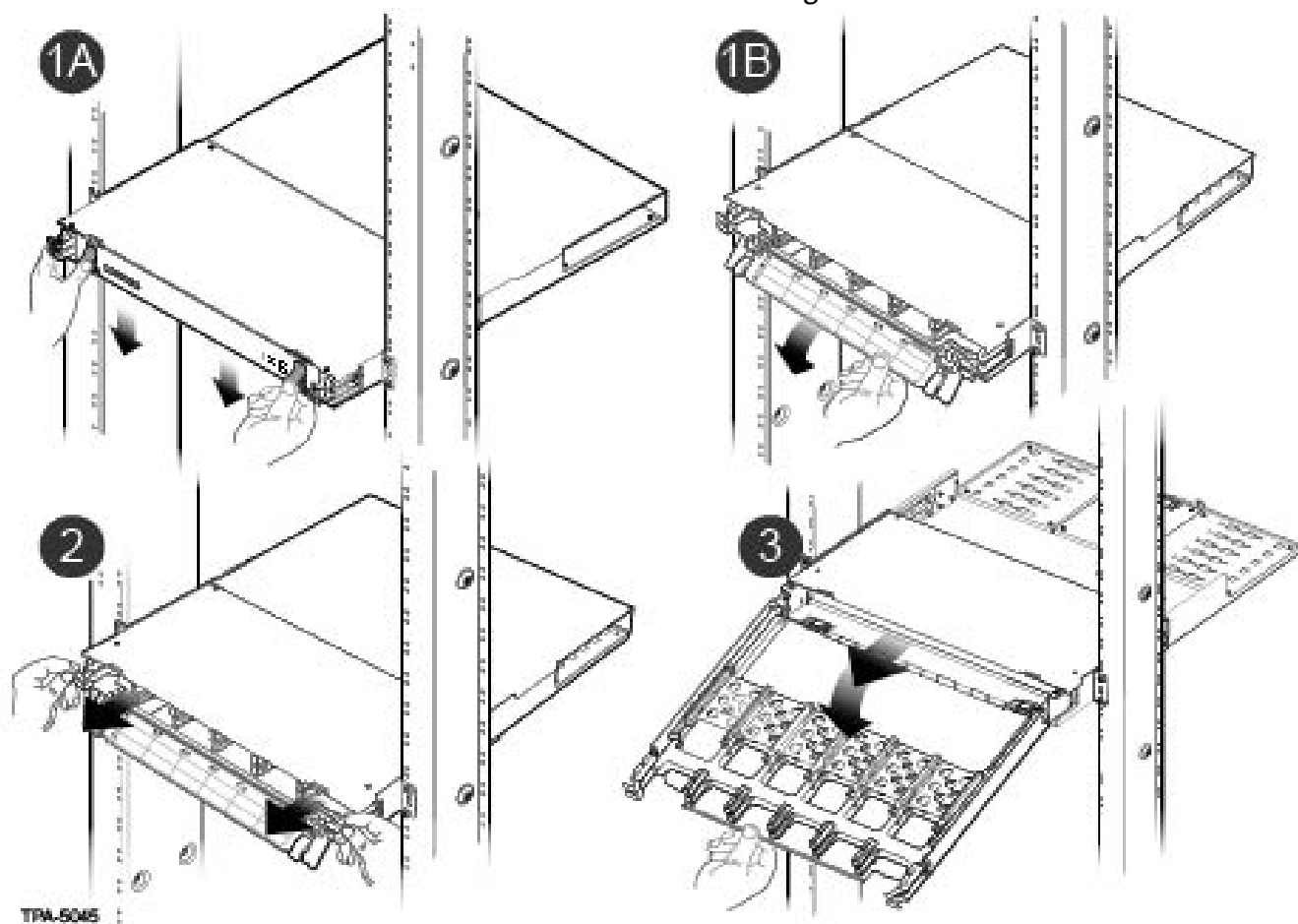

Figure 18— Lower Tilt-down Drawer

**Step 4:** From rear of housing, feed connectorized MTP® trunk connector legs through to the front of the housing.

**Step 5:** From the front of the housing, remove the MTP® connector dust cap by pulling on the dust cap while holding the connector body/housing/shroud (see page 12, Figure 16A). Also remove the module adapter dust cap. For the initial mating, do not clean or scope connectors. Corning CleanAdvantage™ connectors are shipped with an optimized dust cap to maintain cleanliness for the first use.



**CAUTION:** Scoping Corning CleanAdvantage connectors increases the risk of adding contamination to the system. CleanAdvantage technology is designed for mating connectors without cleaning or scoping before the initial installation.

**Step 6:** Mate the MTP connector(s) into the adapter(s) at the back of the module (Figure 19).

**Step 7:** Starting with the lower left corner (Tray 1, slot A, as seen from the front), insert the module from the rear until it locks into place (Figure 19).

**Step 8:** Repeat for all modules.

**Step 9:** Raise tray and slide back into the housing, ensuring connector legs are not pinched in the process.

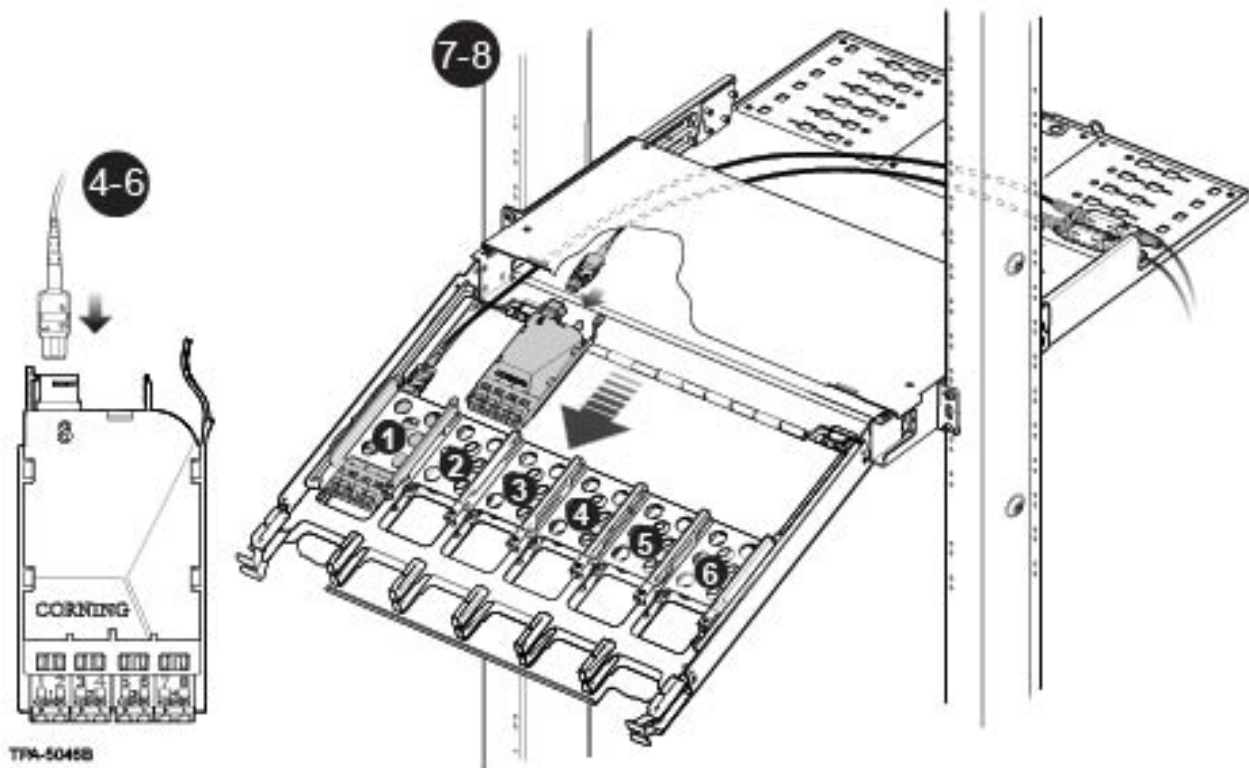

Figure 19 — Install EDGE8® Standard Module

## 4.8 Install EDGE8® Port Breakout Modules

### 4.8.1 Into EDGE8-01U-SP, EDGE8-02U, and EDGE8-04U Housings

**Step 1:** Starting with lower right corner (Tray 1, slot A), insert port breakout module from the rear until it locks into place. Load all trays from right to left, bottom to top in the housing, as seen from the back.

**Step 2:** Loop slack as shown in Figure 20, leaving enough slack to pull out trays without violating the minimum bend radius.

**Step 3:** Repeat for all modules.

**Step 4:** Loosely capture fiber slack with hook-and-loop straps, if desired (Figure 20).



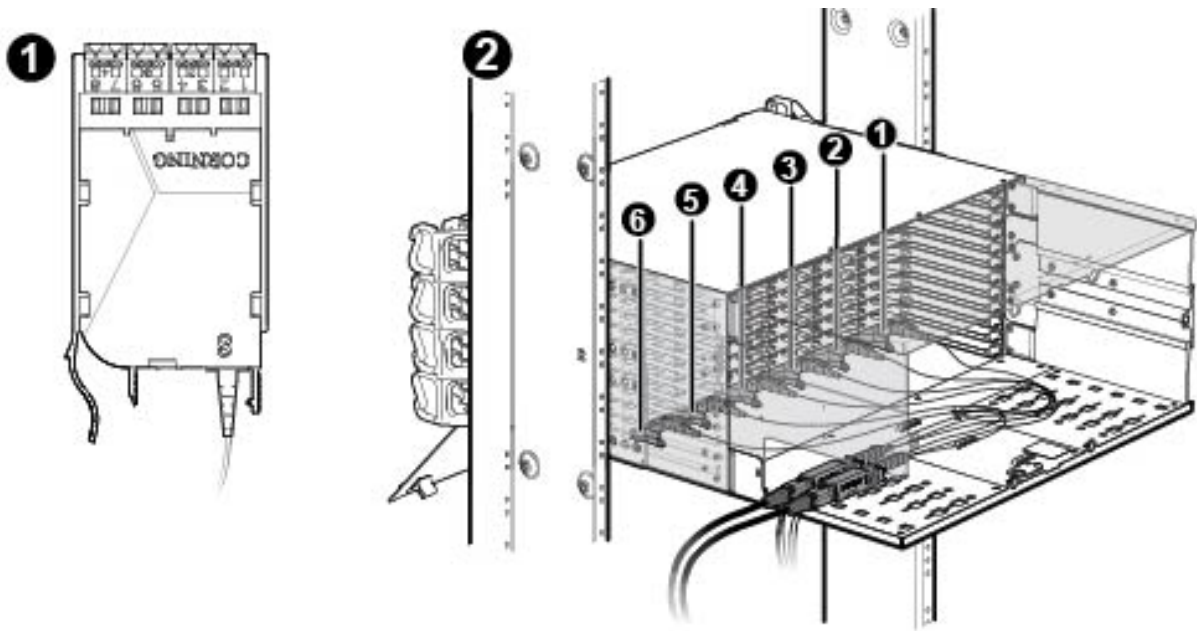

TPA-5070B

Figure 20 — Install EDGE8™ Port Breakout Module

#### 4.8.2 Into EDGE8-01U Housing

**CAUTION:** When removing the trays, position yourself in the center of the rack and use both hands to pull the tray out. Failure to do so may damage the tray guides or cause shelf movement past the detents.

- Step 1:** Press latches down to open and lower front door (Figure 18).
- Step 2:** Using tabs on the side of the drawer, lift and pull out drawer horizontally until reaching hard stops.
- Step 3:** Support the drawer and lower it to the angled position. Remove rear access panel to allow easier access to mount the trunk cables and connect the trunk legs.
- Step 4:** From rear of housing, feed the port breakout module through to the front of the housing.
- Step 5:** Starting with the lower left corner (Tray 1, slot A, as seen from the front), insert the module from the rear until it locks into place (Figure 21).
- Step 6:** Repeat for all modules.
- Step 7:** Raise tray and slide back into the housing, ensuring pigtails are not pinched in the process.

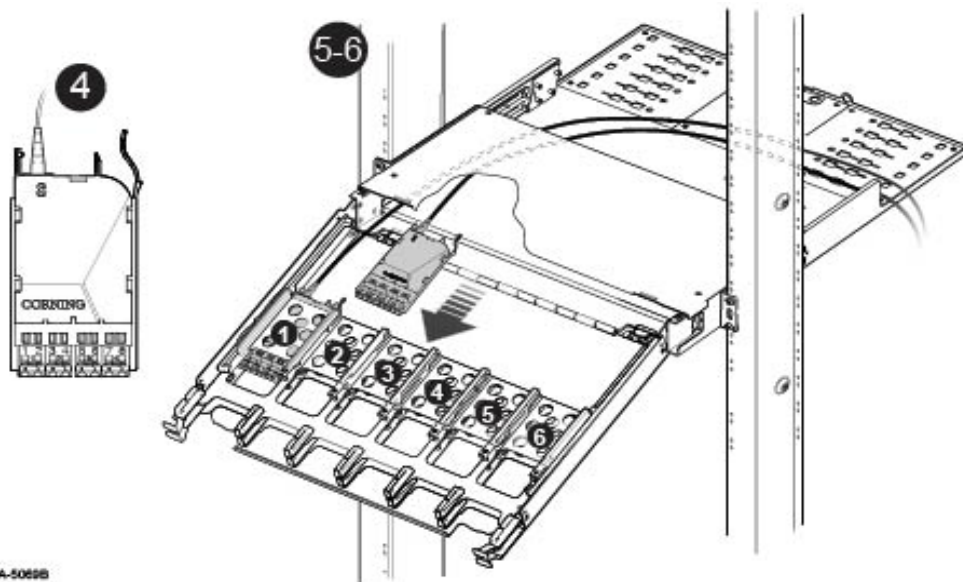

TPA-5065B

Figure 21 — Install EDGE8® Module



## 4.9 Connect Jumpers to EDGE8® Modules



**CAUTION:** When removing the trays, position yourself in the center of the rack and use both hands to pull the tray out.

**Step 1:** Open housing front door and pull out tray (Figure 22).

**Step 2:** For the initial mating, remove dust caps from LC or MTP® connectors on the jumper cables by pulling on the dust cap while holding the connector body/housing/shroud. (See page 12, Figure 16A) For the initial mating, do not clean or scope connectors. Corning CleanAdvantage™ connectors are shipped with an optimized dust cap to maintain cleanliness for the first use.

**NOTE:** Only LC connectors are shown in Figure 19 and Figure 20.



**CAUTION:** Scoping Corning CleanAdvantage connectors increases the risk of adding contamination to the system. CleanAdvantage technology is designed for mating connectors without cleaning or scoping before the initial installation.

**Step 3:** Mate the connectors in the adapters.

**Step 4:** Route jumper legs, half to the right and half to the left side of the housing. (Do NOT cross legs in opposite directions.) Store legs in clips at front of tray (Figure 22).

**NOTE:** *Inspect the jumpers during the routing process to ensure no kinking occurred. If a kink has occurred, re-route the jumper leg to remove the kink.*

**Step 5:** Route the jumper legs per your installation plan to their final destinations.

**Step 6:** Repeat for remaining jumpers.

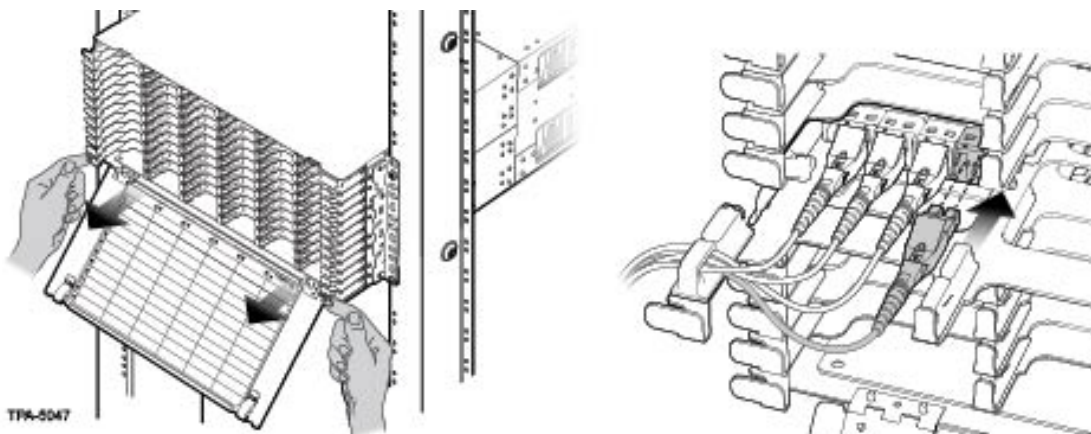

Figure 22 — Mate Jumpers and Route Legs

## 4.10 Install MTP® Adapter Panels

The MTP adapter panel comes in configurations to support both single-mode (SM) and multimode (MM) applications. Adapters have been clearly labeled identifying port (1, 2, 3, etc.). Each tray within the housing will support a maximum of six MTP panels.

Adapter panels may be installed from the front or back of the EDGE8™ housing. During the initial installation, it is recommended to install all panels and all trunk cables into the panels from the rear of the housing. Install panels and trunk cables tray by tray, starting with Tray 1, slot A. Additional panels and trunks should be installed with the same recommendations always working from right to left and bottom to top as seen from the rear of the housing.



**CAUTION:** Previously installed panels that were not fully populated during the initial installation and have a harness, jumper, or trunk connected on the front side of the MTP® adapter panel will require slack from the front in order to be removed from the rear of the housing and install additional trunks. Installer **MUST** obtain slack in the fiber connected to the panels on the front side. Without slack, tension in the jumpers will result in pulling on fiber legs with potentially disrupted service, specifically if disconnect is required.

#### 4.10.1 Connecting MTP Trunk Cable to Rear of MTP Adapter Panel — Initial Mating

**Step 1:** With the trunk cables securely installed in the housing, remove the dust caps from the MTP trunk connector legs and MTP adapter panel (only on the rear side of the adapter panel) by pulling on the dust cap while holding the connector body/housing/shroud. (See page 12, Figure 16A). For the initial mating, do not clean or scope connectors. Corning CleanAdvantage™ connectors are shipped with an optimized dust cap to maintain cleanliness for the first use. Keep dust caps in place on the front of the adapter panel, if applicable.

**Step 2:** Mate the MTP connector(s) into the rear of the adapter(s) (Figure 23).

**Step 3:** Repeat for the remaining adapters and connectors for a single panel. For each panel, group trunk legs and place them in the fiber retaining fingers. Be careful not to pinch or kink trunk legs when placing them in the fiber retaining fingers.

**Step 4:** With a panel fully populated, insert panel from the rear until it locks into place (Figure 24).

**Step 5:** Repeat for all panels.

**Step 6:** Loosely capture fiber slack with hook-and-loop straps in the rear of the housing.

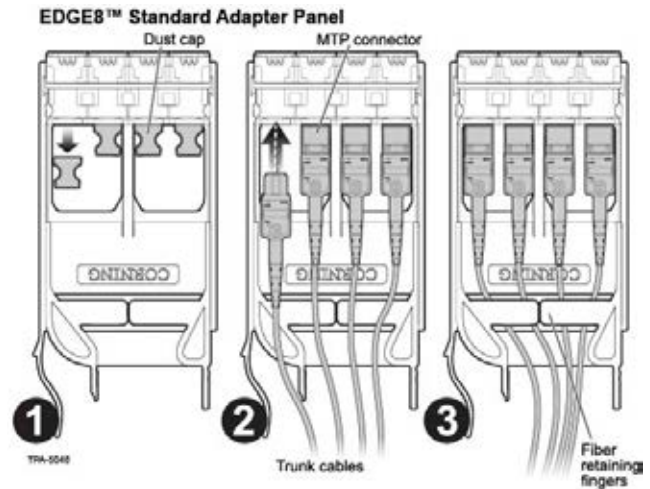

Figure 23 — Install MTP Trunk Cables into Adapter Panel.

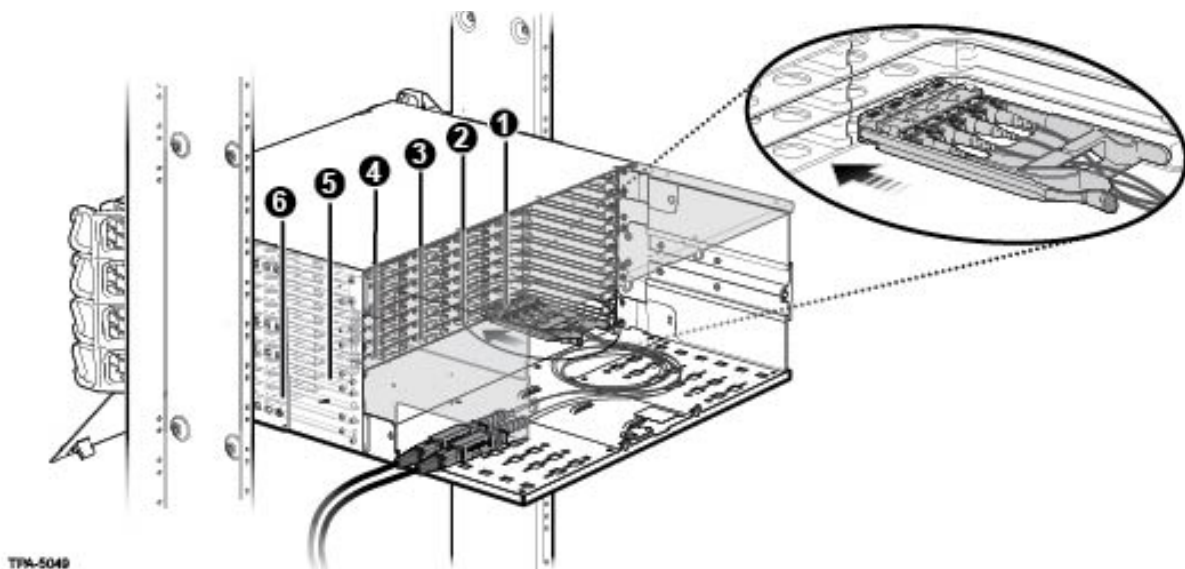

Figure 24 — Insert Adapter Panels into Rear of Housing

#### 4.10.2 Connecting Harnesses, MTP® Jumper, MTP Conversion Harnesses, or Extender Trunk to Front of the MTP Adapter Panels — Initial Mating

**NOTE:** All MTP® harnesses and jumpers are manufactured with MTP PRO connectors. Refer to the MTP PRO instructions in the related literature section for details on how to use the MTP PRO field tool.



**CAUTION:** When removing the trays, position yourself in the center of the rack and use both hands to pull the tray out.



**CAUTION:** Do not exert excessive force on the panel. Damage to the trunk cables may occur.

**Step 1:** Open housing front door and pull out tray. Ensure there is enough fiber slack in the rear of the housing to allow for this movement.

**Step 2:** Remove the dust caps from the front of the MTP adapter panel, if applicable, and the MTP connector of the harness, jumper, or trunk by pulling on the dust cap while holding the connector body/housing/shroud. (See page 12, Figure 16A) For the initial mating, do not clean or scope connectors. Corning CleanAdvantage™ connectors are shipped with an optimized dust cap to maintain cleanliness for the first use.



**CAUTION:** Scoping Corning CleanAdvantage connectors increases the risk of adding contamination to the system. CleanAdvantage technology is designed for mating connectors without cleaning or scoping before the initial installation.

**Step 3:** Mate the connectors in the adapters (Figure 25). If MTP adapter is equipped with shutter, lower the shutter first, then mate the connectors.

**Step 4:** Route the connected cables, half to the right and half to the left side of the housing. Do NOT cross cables in opposite directions. Store the cables or legs in the fiber clips at front of tray. Close the tray.

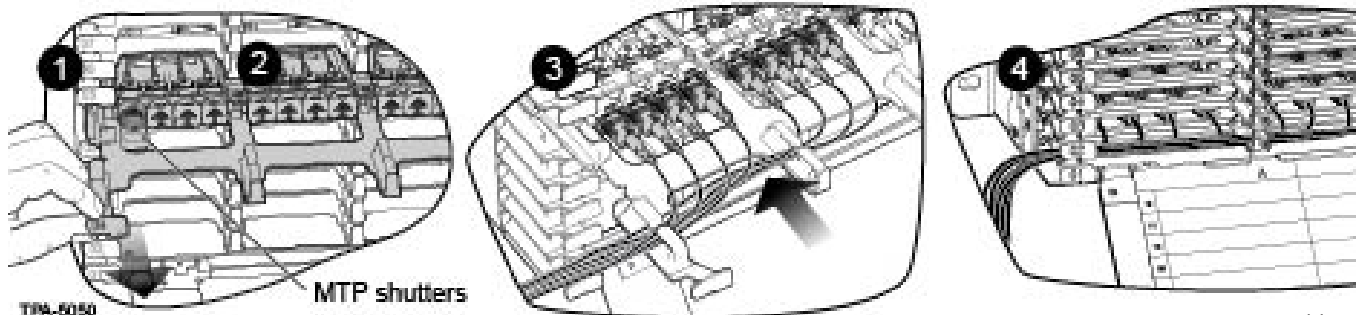

Figure 25 — Route Harness Cable

**Step 5:** Mate the connectors at the end of the harness, jumper, or trunk in the electronics equipment as illustrated in Figure 26 per instructions provided with that equipment, or according to your installation plan.

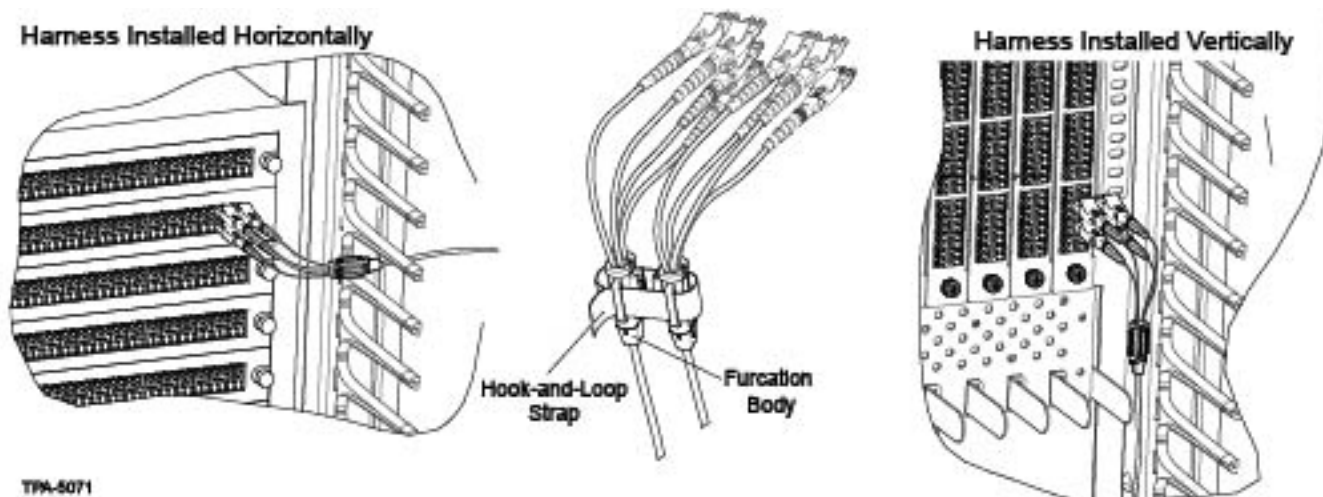

Figure 26 — Typical Harness Configurations

## 5. Recordkeeping

Detailed and accurate recordkeeping enables users to logically “map” fiber terminations within the data center from local equipment to remote equipment. It is recommended that users employ labeling guidelines outlined in ANSI/TIA-606 for mapping the network. Guidelines below provide an analogous solution in accordance with this standard for labeling to be used with the EDGE8® solution. Additions in the suggested coding are accounted for to identify housing/chassis trays and modules.

### 5.1 Hardware Labeling

- Hardware components come pre-labeled for identification and promote a consistent labeling scheme.
- Users must provide their own label maker and media for the frame or cabinet and hardware.
- Labeling is best supported with use of adhesive backed label makers with media up to 1.27 cm (0.5-inch) in height.
- Module positions within each chassis tray are identified by alphabetical characters A through F from left to right.
- Modules or MTP® panels come assembled with adapters and silkscreened with Fiber and/or Port ID.
- Housing/chassis comes equipped with a label card that is easily removable from the inside of the front door and requires no additional fastening to remain in place. This label may be written on, but use of a label maker is better.
- Label card supports adhesive-backed label media and printed labels may be easily adhered or removed for moves, adds, and changes.

Hardware labeling involves a five-step process that identifies the local and remote site. Use the suggested code in Figure 27 and the following steps to map your location. User should print and record the remote location on the provided label card.

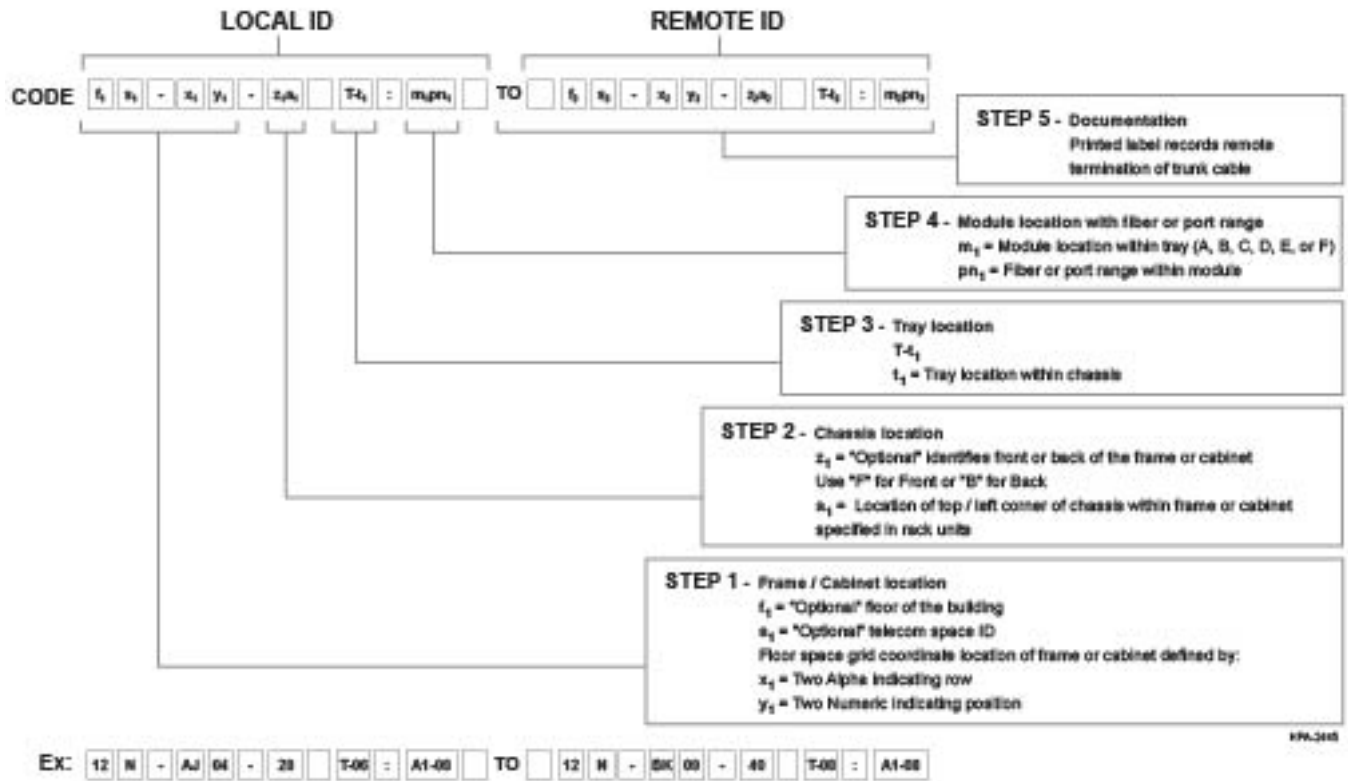

Figure 27 — Recommended Labeling Guidelines

### Step 1: Frame/Cabinet Location (Figure 28)

Identify location of frame or cabinet within the floor space grid coordinate system. Preprint labels and adhere to front and back of frame or cabinet at the top and bottom.

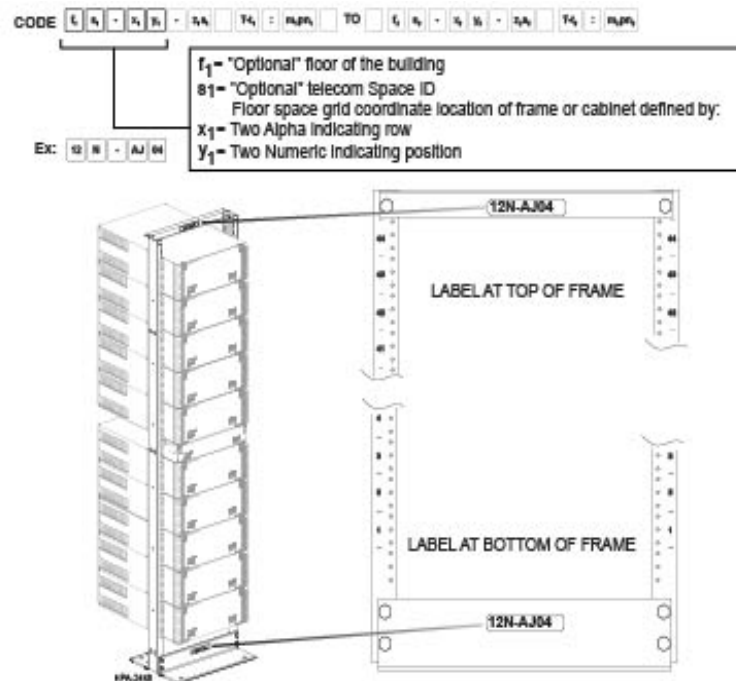

Figure 28 — Frame/Cabinet Label Location

**Step 2: Housing/Chassis Location (Figure 29)**

Identify location within the frame or cabinet (in rack units from the bottom) by locating the top/left corner of the housing/chassis. Print two labels and adhere one to the front chassis door using the crop mark for alignment. Adhere the second label to the label card on the inside of the door.

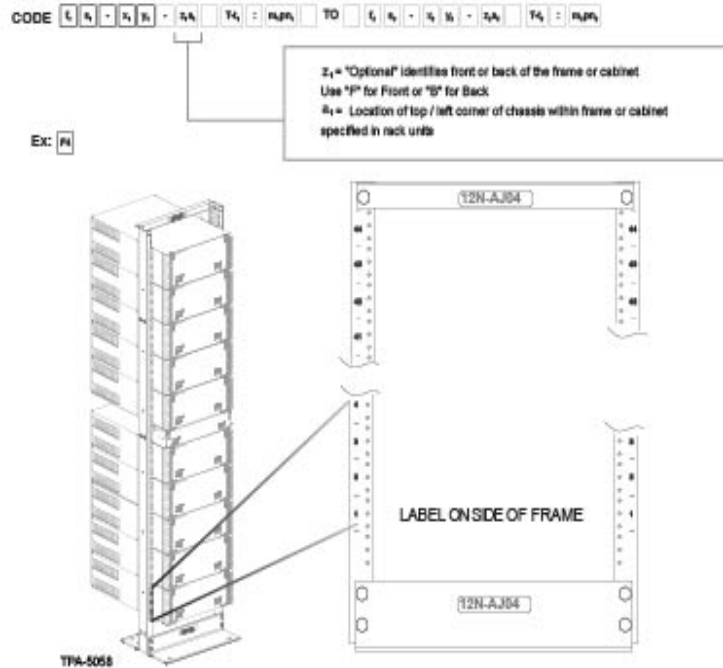

Figure 29 — Housing/Chassis Label Location

**Step 3: Tray Location (Figure 30)**

Identify location of tray within the housing/chassis. Trays come pre-labeled 01 to XX from the bottom to the top of the chassis.

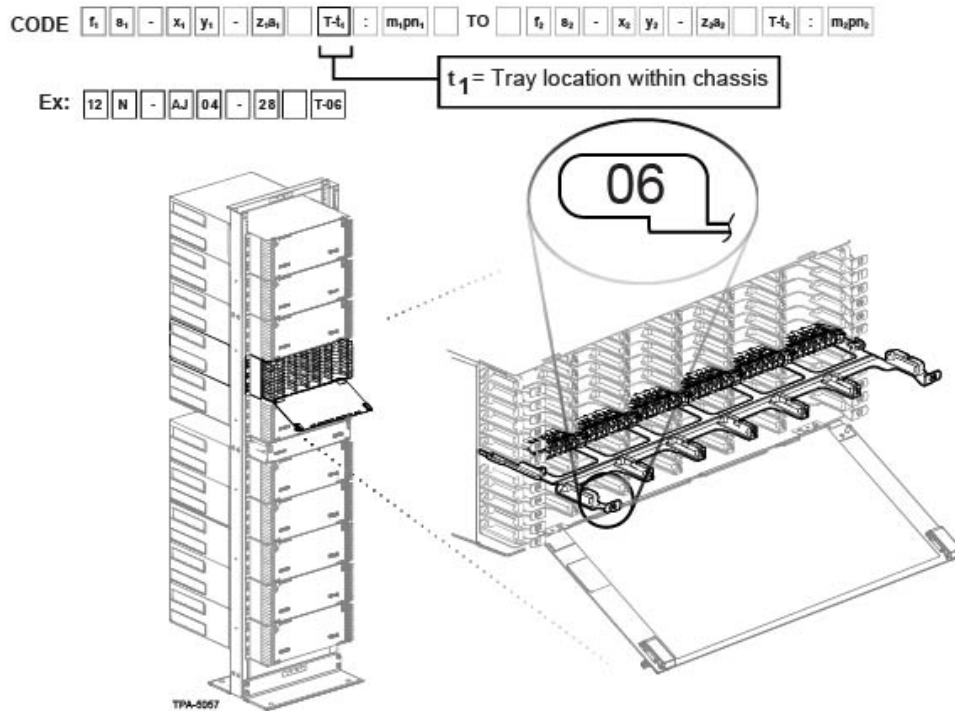

Figure 30 — Tray Label Location



**Step 4: Module Location with Fiber or Port Range (Figure 31)**

Each tray comes pre-labeled A through F to identify module position within the tray.

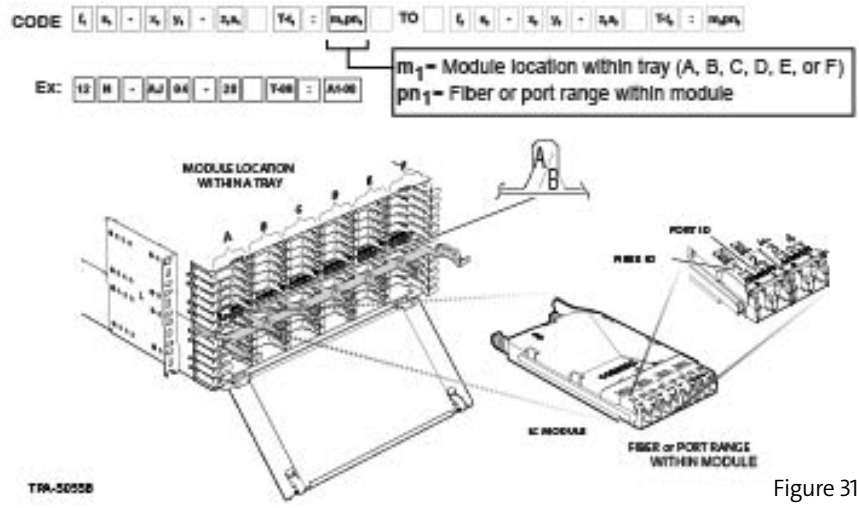

Figure 31 — Module Label Location

**Step 5: Documentation (Figure 32)**

Identify remote location termination and determine code to be printed. It should only be necessary to print the remote location. Printed code from label makers may be affixed to the label card on the inside of the front door.

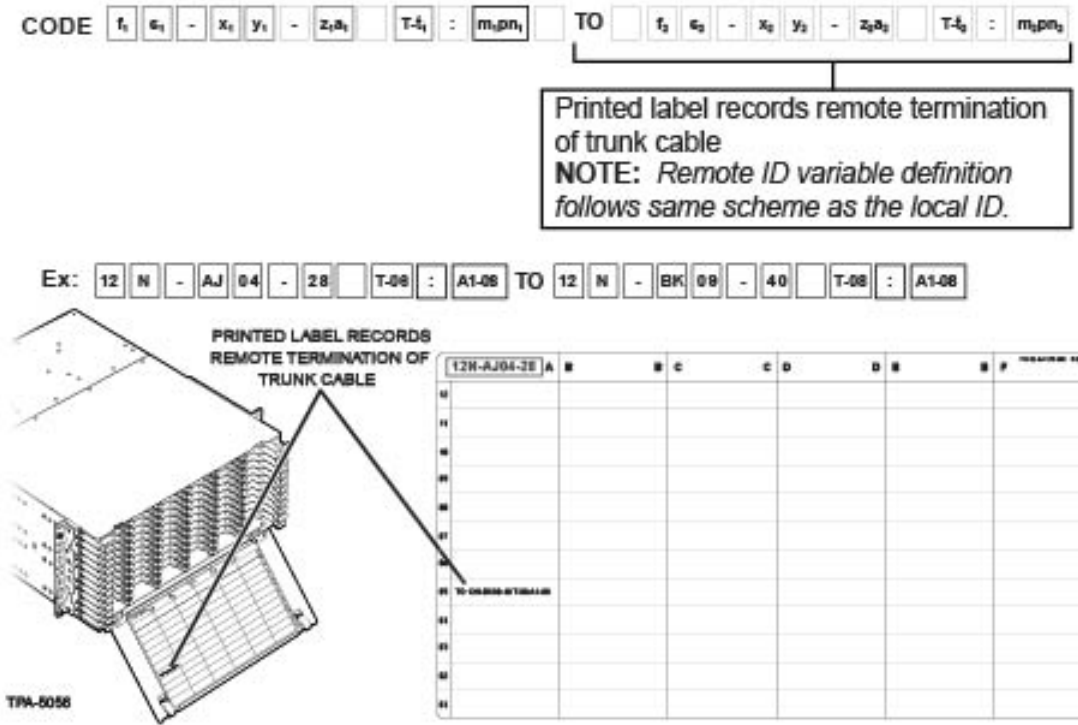

Figure 32 — Print Remote Termination Label



## 5.2 Cable/Jumper Labeling

Fiber termination identification is equally important in mapping the data center network. Individual fibers (such as jumpers) must be clearly labeled to identify local and remote location. Typically a single jumper will contain two labels on each end of the fiber near the termination point identifying the specific local ID and the remote ID the jumper is patching to. It is important to follow suite with previous defined code indicating rack or cabinet ID, patch panel ID and more specifically the individual port or fiber termination location. One should cross reference the recommended guidelines in ANSI/TIA-606. Proper labeling allows users to easily trace jumpers from one location within the network to the next.

Most common identification methods for individual fiber ID employ the use of flag or wraparound preprinted labels. Barrel or snap-on labels may also be employed but user must select the proper barrel label for the corresponding jumper diameter, e.g., 2.0 mm. Documentation should clearly identify individual fiber strands of the cable or jumper.

# 6. Troubleshooting and Maintenance

## 6.1 Testing

Use the Fluke MultiFiber™ Pro Optical Power Meter and Test Kits for testing the MTP® connections. Follow the Fluke Networks manual which can be found on-line at

[http://download.flukenetworks.com/Download/Asset/MultiFiberPro\\_9827313\\_ENG\\_A\\_W.PDF](http://download.flukenetworks.com/Download/Asset/MultiFiberPro_9827313_ENG_A_W.PDF).

A sample test procedure can be seen in Figure 33.

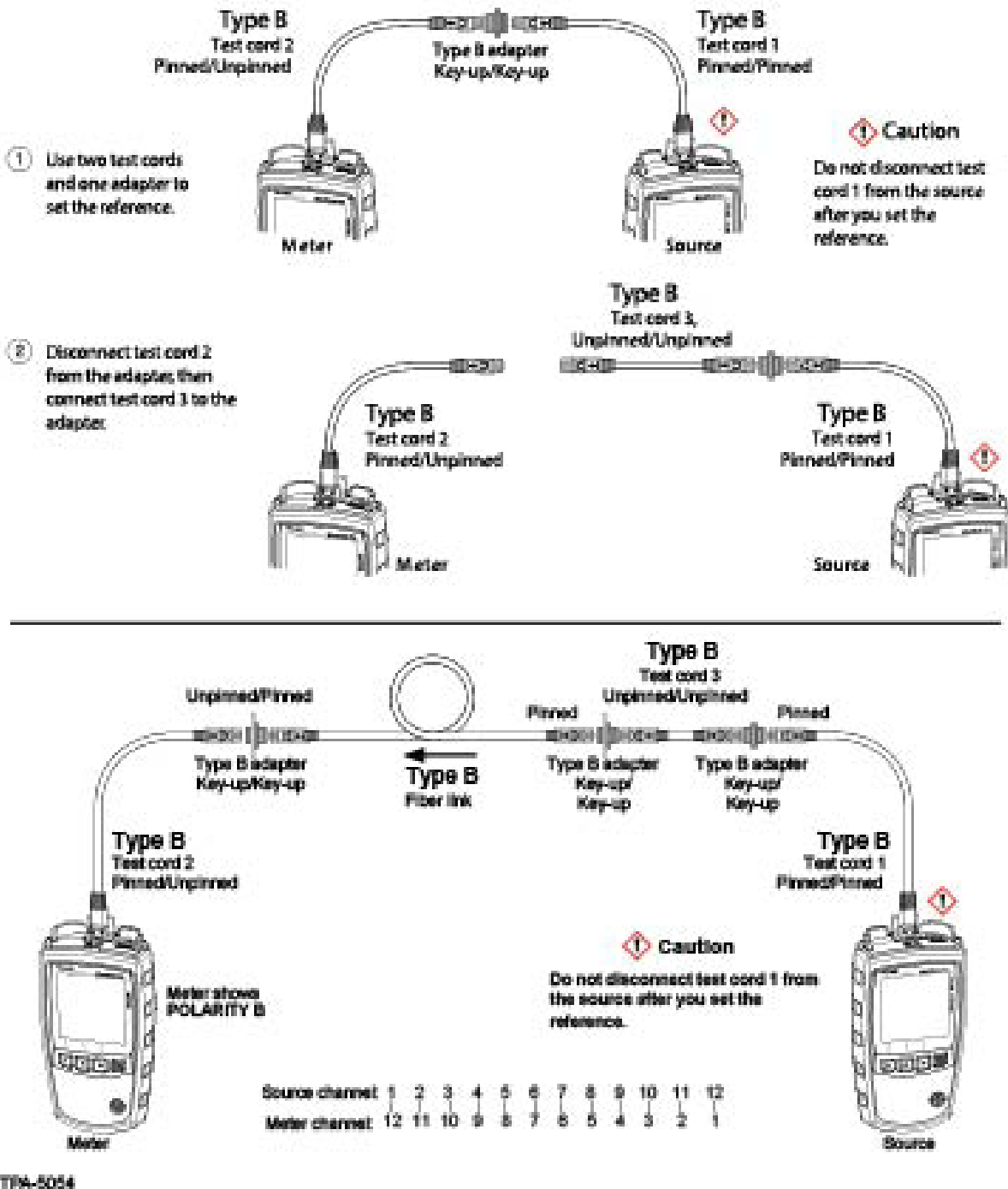

Figure 33\* — Testing MTP Connections

\*Figure 33 provided by Fluke Corporation and used with their permission.

## 6.2 Replace EDGE8® Module

**Step 1:** Open front door and pull tray out.

**Step 2:** Press latch on LC connector and pull connector out (Figure 34). If jumper is equipped with MTP® connector, simply grasp connector body and pull connector out of the adapter. (**NOTE:** only LC connectors shown in Figure 34.)

**Step 3:** Press lever on right side of module and pull module out.

**Step 4:** Unplug MTP connector(s) in rear of module.

**Step 5:** Reverse process to install new module (or panel, if upgrading the network).

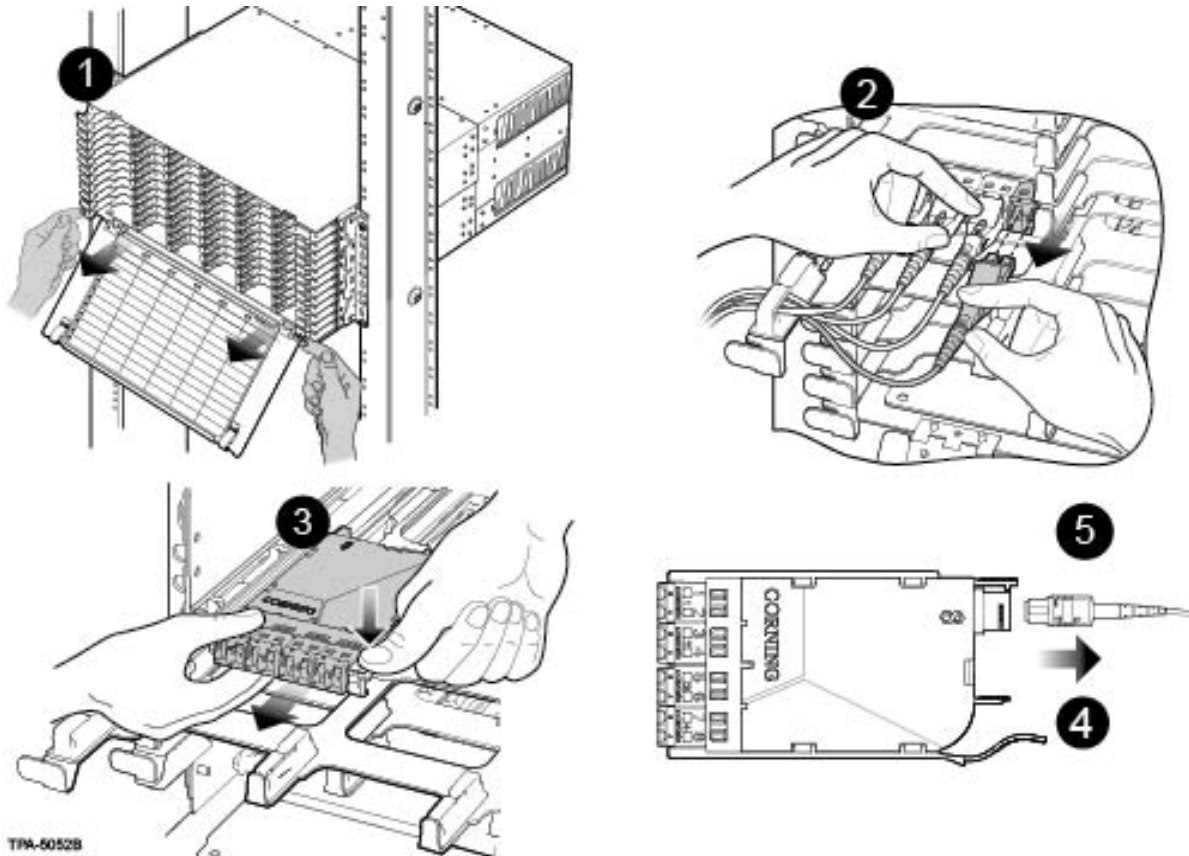

Figure 34 — Replace EDGE8® Module

## 6.3 Remove Trunk Cable

### 6.3.1 Cable in Keyhole Cradle

If necessary to replace trunk cable or keyhole cradle, remove per the directions in this section (Figure 35). Install new cable or cradle per the directions in Section 4.4.

**Step 1:** Pull back on both latches while pushing cradle in opposite direction. Lift cradle and cable up.

**Step 2:** Open cradle door.

**Step 3:** Lift furcation plug out of the cradle.

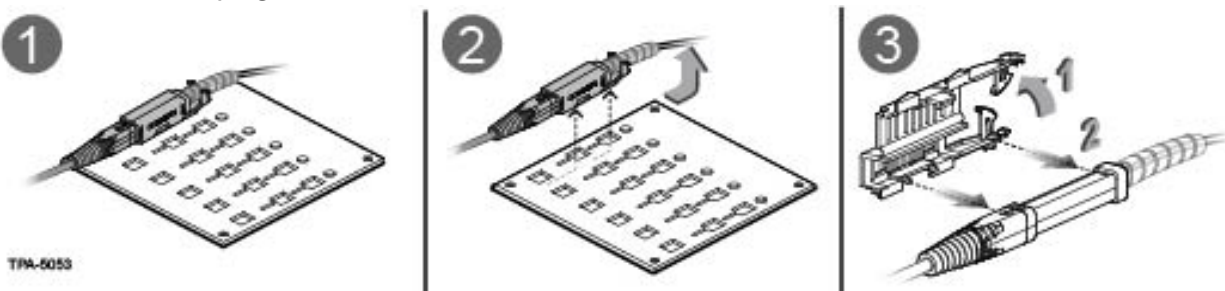

Figure 35 — Remove Trunk Cable in Keyhole Cradle

## 6.4 Changing the Polarity of an LC Uniboot Connector

In some applications, it may be desirable to reverse the polarity of the LC uniboot connector. To do so:

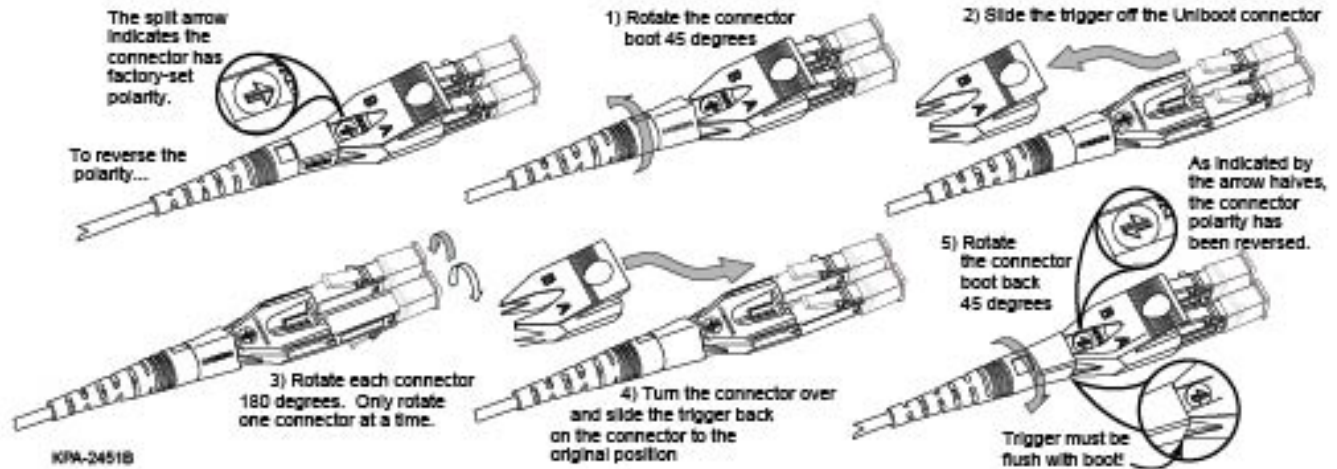

Figure 36 — Reverse Polarity of the LC Uniboot Connector

## 6.5 Changing the Polarity of an MTP® Adapter and Connector

If it is necessary, the polarity of an MTP adapter may be reversed. To do so:

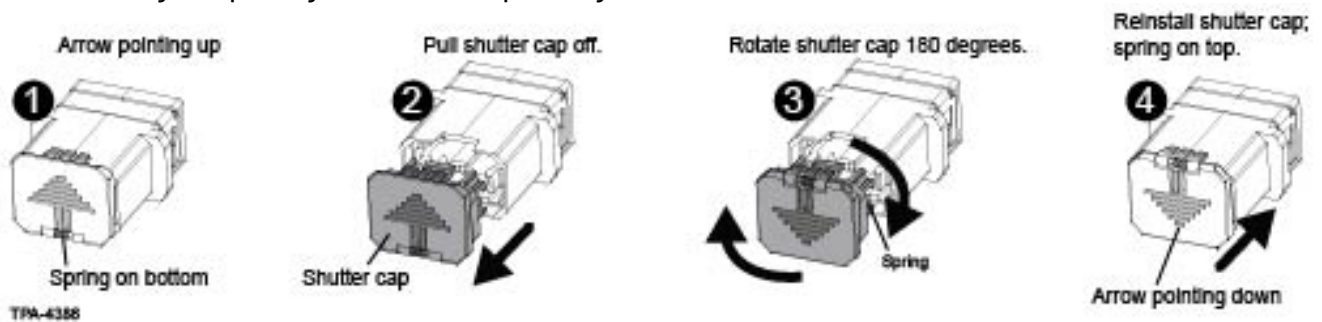

Figure 37 — Reverse Polarity of an MTP Adapter

If it is necessary, the polarity of an MTP connector may be reversed. For instructions, reference Standard Recommended Procedure (SRP) 006-407-QSG-AEN, Field Tool for MTP® PRO Connectors Quick Start Guide.

## 6.6 Connector Care and Cleaning — Post Initial Mating

**NOTE:** Connector care and cleaning should only be necessary after the initial connector mating during testing and troubleshooting of the network.

- a. Clean connectors and adapters using the recommended cleaning tools or kits for the connector type.
  - LC connector and adapter cleaning: use cleaning tool part number CLEANER-PORT-LC
  - MTP connector and adapter cleaning: use cleaning tool part number 2104466-01
- b. Always keep dust caps on connectors and adapters when not in use.
- c. Ensure dust caps are clean before reuse.
- d. When troubleshooting, clean the connector before re-mating, especially for test equipment patch cords (jumpers).
  - Be sure to clean both connectors that are being mated.